



SERVICE MANUAL

FRIIA RANGE:

- 1000861* – FRIIA Chiller/Carbonator
- 1000860* – FRIIA Chiller

* regional variance



Marco Beverage Systems Ltd.
74 Heather Road,
Sandyford Business Park,
Dublin 18,
Ireland

Tel Ireland: 00353 (0) 1 295 2674
Tel UK: 0044 (0) 1933 666 488
Tel US: 206 641 7692
Email: sales@marco.ie

CONTENTS:

1. INTRODUCTION	3
2. MANUFACTURER IDENTIFICATION	4
3. SAFETY INSTRUCTIONS	5
4. BASIC INSTRUCTIONS	6
1. Installation Details	6
2. Green LED Troubleshooting	11
3. Maintenance	11
1. Routine maintenance	11
2. Check for CO2 pressure	12
3. Cleaning the chiller condenser	12
4. Sanitizing	13
5. Cleaning	15
4. Cautions and safety tips	15
5. TECHNICAL DATA	16
1. General Description	16
2. External Arrangement	17
3. R290 Refrigerating circuit	18
1. Overview	18
2. Servicing R290 Equipment	18
3. R290 Refrigerant circuit	19
6. ACCESS TO INTERNAL COMPONENTS	20
7. TROUBLESHOOTING - DIAGNOSTIC GUIDE	31
8. WIRING DIAGRAM	33
9. HYDRAULIC CIRCUIT	34
10. INSTALLATION DIAGRAM	36
11. EXPLODED VIEW	37
1. Outer Frame	37
2. Top bracket	38
3. Front electronic bracket	39
4. Pump bracket	40
5. Base	41
12. SPARE PARTS	42

1. INTRODUCTION:

The information provided in this manual is intended to assist in the installation and maintenance of the MARCO FRIIA Chiller and Chiller/Carbonator. Please read the instructions carefully to prevent accidents and ensure an efficient installation.

This manual is not a substitute for any safety instructions or technical data affixed to the machine or its packaging. All information in this manual is current at the time of publication and is subject to change without notice.

Only technicians or service providers authorised by MARCO should carry out installation and maintenance of these machines.

Marco Beverage Systems accepts no responsibility for any damage or injury caused by incorrect or unreasonable installation and operation.

<p>WARNING: The refrigerant R290 (Propane) is flammable and it must be handled only by competent and responsible operators, under the conditions specified in the safety regulations in force.</p>	 <p>8122-2</p>
---	---



<p>DO NOT SMOKE</p>	<p>NO NAKED FLAMES</p>
	

2. MANUFACTURER IDENTIFICATION

i *Unless otherwise stated, pictures are generic and for reference only, and they are subject to technical change without prior notice.*

i *The manufacturer reserves the right to modify the product and the relative technical documentation at any time and without notification, and cannot be held liable for any errors or inaccuracies in the contents of this manual.*
This version of the use and Maintenance Manual describes the characteristics of the standard production equipment as of the date of printing.

Contact Marco Beverage Systems for any technical queries or to order spare parts.

When replacing equipment parts, you are advised to use original spare parts; the manufacturer cannot be held liable for any reduction in equipment performance or damage caused by the use of non-original parts.

3. SAFETY INSTRUCTIONS:

- Read all instructions.
- To protect against electric shock do not immerse mains cord in water or other liquid.
- To prevent fraying of the cable, do not let the mains cord hang over the edge of a table or counter ; or touch hot surfaces.
- Do not operate any appliance with a damaged cord, plugs, or after the appliance malfunctions or has been damaged in any manner.
- Switch off at the mains (unplug or disconnect from outlet) and turn off the water supply when not in use and before cleaning. Allow to cool before removing components.
- The use of spares and accessories not recommended by Marco may cause damage and/or injuries.
- Do not use outdoors. Do not place on or near a hot gas or electric burner.
- Do not use the appliance for anything other than its intended use.
- Save these instructions.

4. BASIC INSTRUCTIONS:

4.1. INSTALLATION DETAILS:

Positioning

- The equipment must be placed on a surface capable of bearing the weight of the chiller complete with water. Install the equipment following the schematic described in this user guide.
- The chosen position must in any case allow satisfactory ventilation; in particular, there must be a gap of at least 10 cm (3.9 in) around the back and top for ventilation.
- The equipment must not be placed close to direct or indirect heat sources (ovens, stoves, radiators, etc.).
- The electrical connection and water supply points must be close to the equipment and located in such a way the power cable and water hose do not form an obstruction.
- The appliance must not be installed where water jets can be generated. Do not spray water on the device; this could cause electric shock or fires.

Electrical installation:

- Electrical specification: 180W-230V-50Hz.
- Electrical specification US: 180W-110V-60Hz.
- A moulded IEC C13 power cord is provided. This should be plugged into the IEC connection on the back of the chiller, then plugged into a suitable power outlet.
- A US 3 Pin (NEMA 5-15P) plug to C13 IEC is provided with the 110V chillers.

Plumbing installation procedure:

- Mains water pressure not to exceed 10 Bar.
- To ensure that the maximum value of pressure of 3 Bar is not exceeded the chiller integrates a pressure reducer.
- Ensure that the equipment is installed according to local plumbing & water regulations.
- Fit a stop valve on the 3/8" cold water line.
- Make sure the pipe is pushed fully into the fitting; Make sure that, when required, the pre-attached sealing washer is fitted.
- Turn on the water to flush any impurities, dust etc from the inlet hose and water pipe. Allow several liters through. Especially for new installations.
- Connect water supply lines following the installation drawings.
- If the filter is new, turn on water and flush at least 10 liters (2.5 gallon) through the filter before connecting it to the cooler.
- Connect the 3/8" hose to the inlet elbow of the chiller. Make sure the pipe is pushed fully into the fitting.
- Turn on water and check for leaks.

Backflow prevention

- This equipment must be installed with adequate backflow prevention to comply with all applicable federal, state and local codes.
- **NSF compliant version already integrates a backflow prevention device ASSE1032 certified with a dedicated 100 mesh strainer; both devices are enclosed in a stainless steel frame with dedicated hydraulic fittings.**

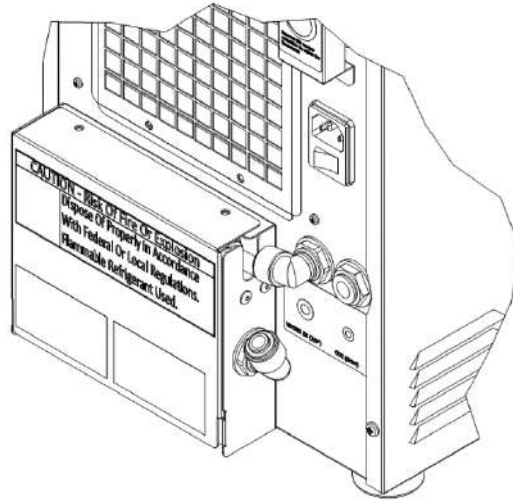

- **Do not remove and / or tamper the assembly unit and the existing dedicated water connections.**

CO2 installation procedure

Connect CO2 using the appropriate 8mm polyethylene tube.

CO2.

- Only use super-dry food grade CO2. Before connecting the pressure reducer to the gas cylinder, always vent any dirt from the valve and close the cylinder valve after few seconds.

GAS CYLINDER LOCATION

- To prevent the risk of injury or damage, the CO2 cylinder must always be kept in a vertical position against a wall, held in place by a chain and fixed to a bracket. Do not expose the bottle to heat sources or very low temperatures.

PRESSURE REDUCERS

- There are different type of CO2 cylinder available. Always use a pressure reducer suitable for the type of valve on the cylinder.
- Please use dual gauge CO2 regulator PN 1400195 (EU) and 1400196 (US).
- Check for leaks using a solution of soapy water.
- If you have a CO2 leak ventilate the contaminated area at once.

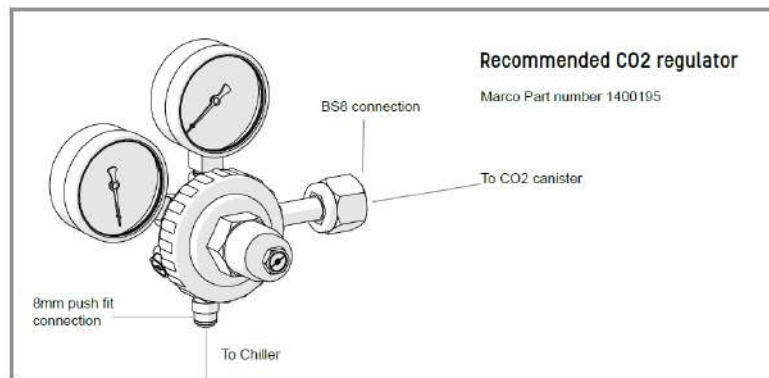

1400195 (EU) - Dual Gauge CO2 Regulator 4.8bar (BS341 No8 (0.860" x 14tpi))

1400196 (US) - Dual Gauge CO2 Regulator 4.8bar US (CGA 320 thread)

Carbonation pump

- The device is equipped with a carbonation pump required for the addition of carbon dioxide in the water. After about 3.5 minutes of continuous operation, without the usual stops and starts dictated by the carbonation level probes (obvious symptom of leak of water in the feed), the pump shuts carbonation and the LED on the front of the chiller starts blinking. To reset this simply disconnect and then reconnect the power to the equipment.

Thermostat setting

- The temperature of the dispensed beverages can be adjusted using the thermostat on the back of the chiller.
- To avoid an accidental change of the set point, the thermostat is protected by a tamper protection; remove the protection to access the thermostat knob.
- If the knob is turned in a clockwise direction the water will be cooler, if turned in the opposite direction water will be less cool. If the thermostat knob is turned completely anticlockwise (to “0” or “STOP” position), the compressor turns off.



POSITION	APPROX OUTPUT TEMPERATURE (°C)	APPROX OUTPUT TEMPERATURE (°F)
STOP	Compressor OFF	
1	2,5 ± 1	36,5 ± 1
2	4,5 ± 1	40 ± 1
3	6,5 ± 1	43,5 ± 1
4	8,5 ± 1	47,5 ± 1
5	10,5 ± 1	51 ± 1
6	12 ± 1	53,5 ± 1
7	13 ± 1	55,5 ± 1

Operating chiller for the first time:

- Before connecting the appliance to the power source, let it stand upright for approximately 2 hours. This will reduce the possibility of a malfunction.
- Check that all installation procedures have been carried out.
- Ensure water valve is on.
- Ensure CO2 valve is open.
- Before supplying power to the unit check water and Carbon Dioxide lines do not leak.
- Plug the chiller into a suitable socket with an ON/OFF switch.
- Push the ON/OFF switch at the rear of the chiller to ON position.
- Plug the boiler into a separate suitable socket with an ON/OFF.
- Push the ON/OFF switch on rear of the boiler to ON position.
- The “Power ON Status” light will light-up.
- Set the boiler to UC single (page 21).
- When the chiller unit is on, the carbonation pump starts to fill. The carbonation device stops when it reaches the maximum level.
- Open the PRV vent on top of the Chiller by pulling the ring. This operation allows the escape of any air bubbles present inside which would affect the carbonation adversely.
- On the pressure reducer knob, adjust CO2 pressure to a value between 50 and 65 PSI (350 and 450 kPa) (3.5 - 4.5 bar) This value depends on the temperature of the water and on the ambient temperature.
- To enable the filling of lines, push the font buttons in the following order sparkling water, Cold water & hot water until the flows appear.
- At this point you can dispense water.

Environmental condition

- The equipment is not suitable for external use.
- The equipment must be placed so it is protected from rain and water splashes, and in a location with the temperature appropriate to its climate class (stated in specification); otherwise warranty rights are forfeited and malfunctions may occur.

4.2 GREEN LIGHT TROUBLESHOOTING:

After about 3.5 minutes of continuous carbonation pump operation, without the usual stops and starts dictated by the carbonation level probes the internal carbonation pump controller shuts carbonation pump and LED starts blinking.

Refer to Troubleshooting chapter of this manual for corrective actions.

4.3 MAINTENANCE:

4.3.1 ROUTINE MAINTENANCE:

To always ensure good equipment operation, certain maintenance procedures (described below) are required.

DAILY MAINTENANCE

1. Water font

Clean the font nozzle and remove any residual using warm water; do not use solvents or abrasive detergents. If needed, remove all the limestone with a food descaling solution.

2. Drip tray

Clean the drip tray and remove any residual using warm water.

3. CO2 pressure

Review pressure CO2 gauges for proper settings.

4. Power cord

Check the condition of the power cord. Replace if necessary.

4.3.2 CHECK FOR CO₂ PRESSURE:

Review pressure CO₂ gauges for proper settings.

DANGER



ELECTRICAL MAINS

Always isolate chiller from power supply before doing any work on it, to prevent damage and health hazards.

Replacing a carbon dioxide (CO₂) cylinder

When the needle of the reducer high pressure gauge is in the red segment, the cylinder needs replacing:

1. Note down the pressure values set on the pressure reducer, then fully close the bottle using its valve.
2. Remove the pressure reducer (or disconnect the high pressure hose from the bottle, if fitted). Check the condition of the gaskets between the reducer and the bottle, replacing them if necessary.
3. Replace the CO₂ cylinder, slowly open the valve to its fully open position, and check that the pressure values are as originally set.

4.3.3 CLEANING THE CHILLER CONDENSER:

Check the chiller condenser at regular time intervals, in accordance to environmental conditions (humidity and dust).

If dust or dirt accumulates between the condenser blades, remove screws, plastic clips and the removable upper panel and clean condenser fins using a soft brush, a vacuum cleaner or low-pressure compressed air.

Remove any dust from the cooling and electrical components.



*Accumulation of dust and grease over the condenser may cause overheating, and this in turn could damage the compressor beyond repair.
The condenser must always be cleaned when necessary.*



Do not use wire brushes and compressed air jets because they can damage condenser fins.

4.3.4 SANITIZING:

CAUTION



Before carrying out the following operations, carefully read the instructions given by the sanitization product manufacturer and make sure all personal protective equipment (gloves, masks, etc.) is worn correctly. The sanitization of the product lines must only be carried out by specialized technical service personnel. During the sanitization operations, attach a warning sign to the tower concerned, to inform any other personnel that this operation is in progress, and that it is forbidden to dispense beverages.

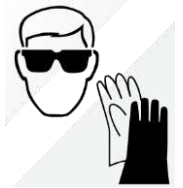

This procedure should only be carried out by persons trained by Marco Beverage Systems or their approved distributors.

The operation of higienization/sterilization has to be carried out every time the refrigerator is installed and:

- every 6 months when it is used.
- every time the water filter is changed.
- after an inoperative period of one or more weeks.

If the refrigerator is installed in Hospitals, Schools, Elderly people's homes, or Clinics, it is recommended to sterilize it every 3 months.

Use a suitable product that is both a detergent and a sanitizer, to be mixed with water in the proportions recommended by the manufacturer. Marco Beverage Systems recommend Bioguard Internal Water Cooler Sanitiser. We suggest to change the product type on a regular basis too, to prevent resistant bacteria from becoming established.

Never exceed the contact times and maximum dosage concentrations recommended by the manufacturer. Once the sanitizing fluid has flowed through and cleaned the lines, they must be thoroughly rinsed with mains water until all the sanitizer has been completely eliminated. Check the pH of the outlet water is the same as the pH of the inlet water (use litmus paper or a pH meter).

PREPARE THE COOLER FOR THE SANITIZATION

1. Turn on water and flush at least 4 liters (1 gallon) through entire system (plain and carbonated water circuits).
2. Uncouple water line from main water supply.
3. Dispense plain water.
4. Dispense carbonated water until CO₂ only comes out.
5. Close the CO₂ cylinder and dispense carbonated water to remove CO₂ pressure completely. (alternatively pull the PRV ring on the top of the chiller).

SANITIZING

1. Turn off Electrical Power Supply.
2. Replace the filter cartridge with a sanitizing filter recommended by Marco Beverage Systems and fill with clean water and with sanitizing fluid in the concentration and contact time recommended by the manufacturer.
3. Disconnect the water connections and connect them to the sanitization cartridge.
4. Turn on water mains and Power Supply Mains.
5. Note position of temperature adjustment knob and then turn it to off position.
6. NOTE: Container and drain basin will be required to collect water from the font.
7. Flush all lines (Ambient, Cold and Sparkling) with sanitizer until you can smell the sanitizing product which may have a characteristic smell, or see the colour of the liquid (in the case of coloured products), or using colorimetric test strips, to be sure the entire line is filled with the sanitizing liquid.
8. Alternate the dispensing operations every 15 seconds, respecting the maximum product usage time recommended by the manufacturer (failure to respect the exposure time may cause damage to the system).
9. Reconnect chiller to regular water supply.
10. Return temperature adjustment knob to its original position.
11. Flush the lines with mains water.

4.3.5 CLEANING:

DANGER



ELECTRICAL MAINS

Always isolate chiller from power supply before doing any work on it, to prevent damage and health hazards.

The exterior of these machines may be cleaned with a damp cloth and a light detergent. Do not use abrasive cloths or creams, as this will spoil the finish of the machine. Do not use a water jet or spray.

ATTENTION



Do not spray water on the device; this could cause electric shocks or fires.

4.4 CAUTIONS AND SAFETY TIPS:

- This appliance must be earthed. If the moulded plug supplied is not used then ensure that the green/yellow cable is connected to a suitable earth.
- Risk of flooding. The hose supplied with this unit is non-toxic food quality tested to 190psi (1300 kPa). However, a hose is not a permanent connection. It is, therefore, advisable to switch off chiller and close the stopcock valve when chiller is not in use, e.g. overnight, weekends etc.
- The utmost care has been taken in the manufacture and testing of this unit. Failure to install, maintain and / or operate this chiller according to the manufacturer's instructions may result in conditions that can cause injury or damage to property. If in any doubt about the serviceability of the unit always contact the manufacturer or your own supplier for advice.

5. TECHNICAL DATA:

5.1 GENERAL DESCRIPTION:

FRIIA Specifications	
Max Dimensions (W/D/H)	Width: 259 mm Depth: 436 mm Height: 457 mm (w/feet and Overpressure valve)
Voltage and frequency ratings	230 V/50 Hz 110V/60 Hz
Max Power consumption	200 W
Compressor nominal power	1/8 HP
Refrigerant type and quantity	R290 / 45 gr
Carbonator volume	1 lt
Net Weight	35 Kg

5.2. EXTERNAL ARRANGEMENT:

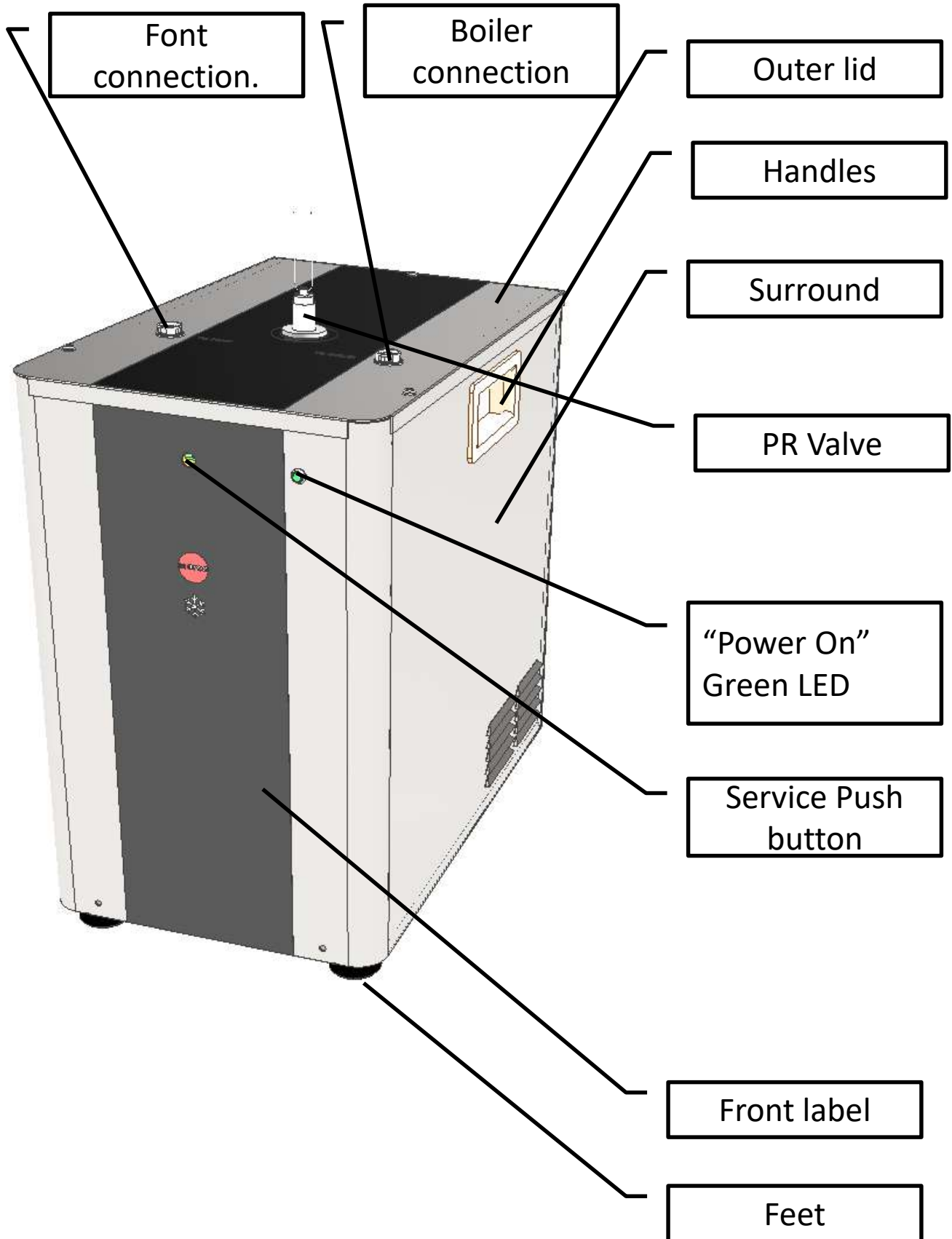

5.3. R290 REFRIGERATING CIRCUIT:

5.3.1. Overview:

What is R290?

- Common name for high purity propane (C₃H₈) suitable for use in the refrigeration and air conditioning industry.
- Hydrocarbon (HC) refrigerant.
- Proven safe, not an environmental threat – has been used in international markets for 10+ years.
- Already used in coolers, display cases, and chill cabinets.

Why not R134A?

- EPA and UE plans ban on R134A, effective between 2019 and 2022.
- Most beverage cooler manufacturers moving to R290 as the alternative to R134A refrigerant.

5.3.2 Servicing R290 Equipment:

R290 Service Overview

- It is propane, so it is flammable. You MUST observe caution and proper safety practices when servicing R290 refrigeration systems.
- Servicing refers to making repairs to the hermetically sealed system and any part of the electrical system. The EPA and UE set a limit, 150 grams/ 5.29 ounces, on the amount of R290 charge for commercial applications.
- Repair on R290 systems must always be done in a well ventilated area.
- Because R290 is highly flammable, a combustible gas leak detector is required when servicing R290 systems.

Servicing R290 vs. R134A

- Operationally very similar systems.
- Operating pressure of R290 system slightly higher than an equivalent R134A system.
Example:
 - At 38°C/100°F, evaporating pressure in an R290 system is approx. 46 psig/4,2 Bar.
 - At 38°C/100°F, evaporating pressure in an R134A system is 26.6 psig/2.84 Bar.
- (See pressure chart in upper right column.).
- Refrigerant charge in an R290 system is 40 – 60% less than an equivalent R134A system.
- **Only Marco technicians or service providers trained on procedures for handling R290 refrigerant gas can carry out repairs on the chillers charged with R290.**

5.3.3 R290 Refrigerant circuit

What are R290 refrigerant circuit components?

- Compressor and copper pipes welded on the compressor;
 - Priming pipe
 - Suction pipe
 - Filling pipe with its cap.
- Condenser and condenser pipes, priming pipe from compressor and filter pipe to filter/drier.
- Filter/Drier.
- Capillary pipe, the lamination device, welded between the filter/drier out and the evaporator inlet.
- Evaporator, the stainless steel tube, with a 8mm diameter integrated in the Alublock.
- Suction pipe, welded between evaporator and compressor.

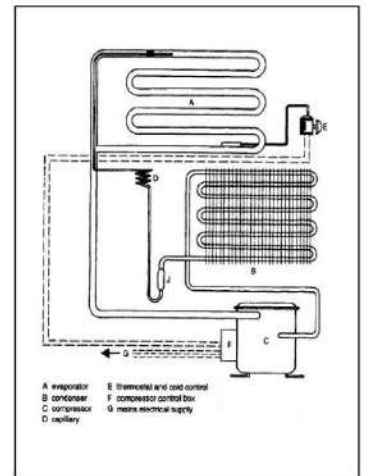
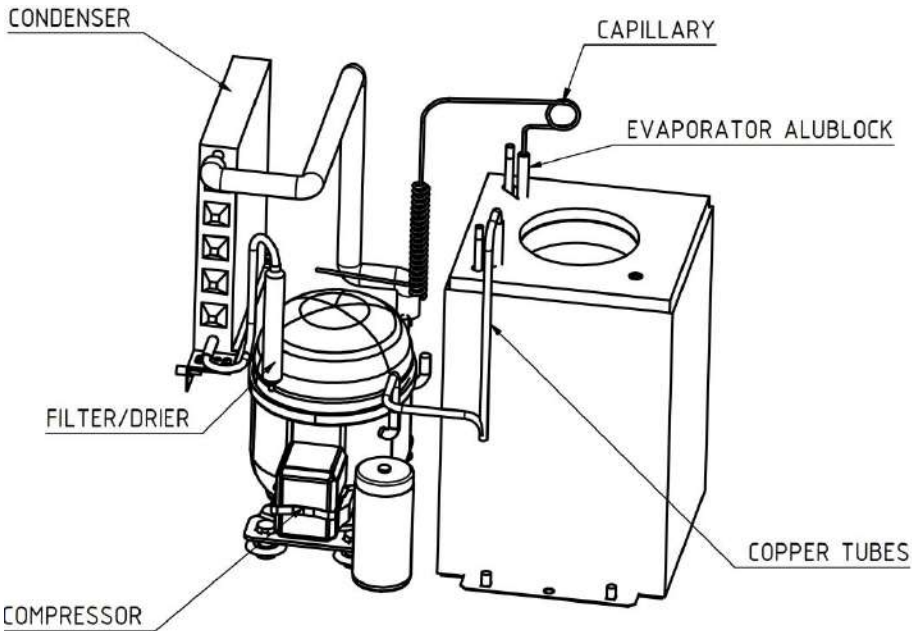

6. ACCESS TO INTERNAL COMPONENTS:

To inspect the chiller from the top:

1. Disconnect the machine from the electrical supply.
2. Disconnect all water and CO2 connectors.
3. Purge the CO2 from the machine.
4. Allow to cool sufficiently.
5. Remove the outer lid. To remove outer lid, undo 3 Phillips Screws.
6. Release intermediate BOILER and FONT harness connection.
7. Carefully remove the lid as not to damage the PRV or the wiring harnesses.



To access to internal components.

1. Disconnect the machine from the electrical supply.
2. Allow to cool sufficiently.
3. Remove the outer lid. To remove outer lid, undo 3 Phillips Screws.
4. Remove surround, To remove surround, undo 2 Phillips Screws on front and 4 on back.

Place the panels to the side of the machine. This allows access to most of the internal components and the machine needs to be drained for most maintenance or service operations.

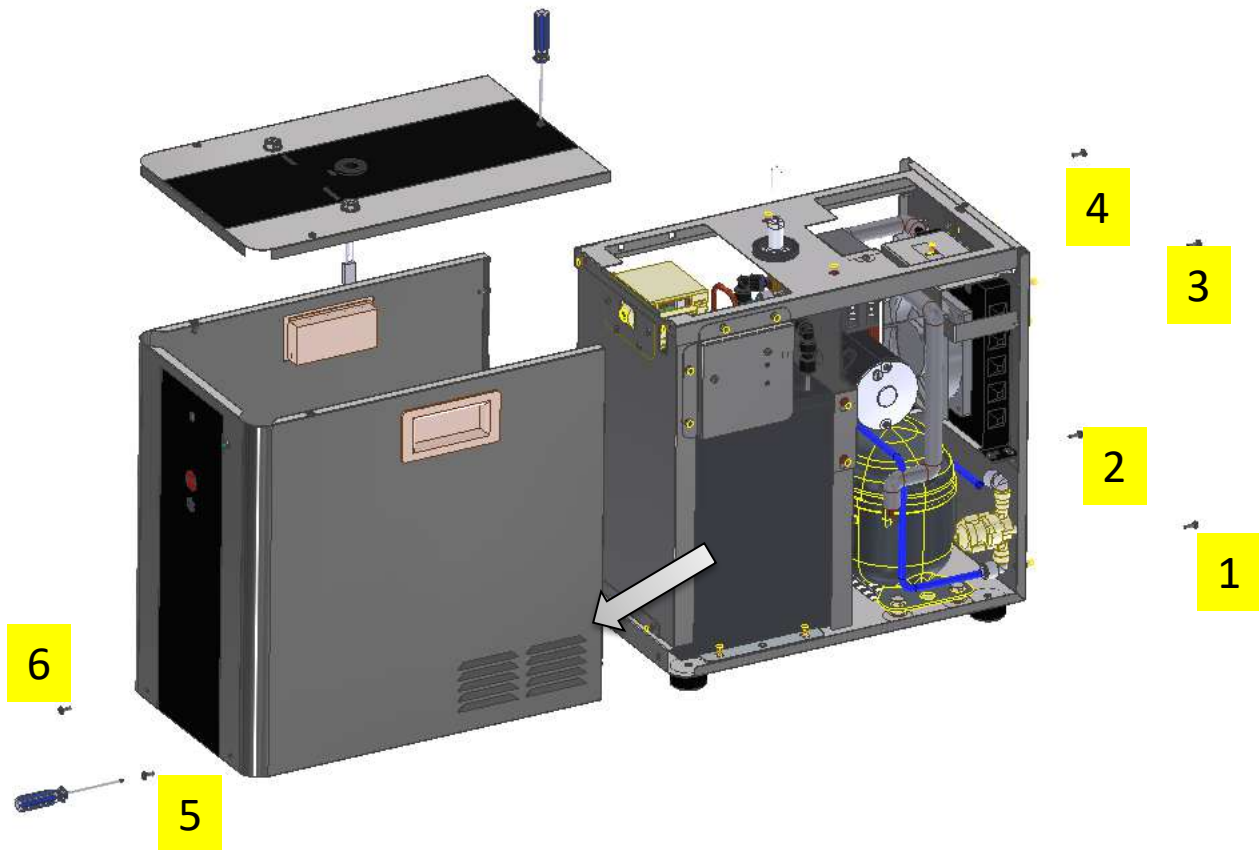

Inlet Pressure Regulator

Sporadically, dust or iron particles from the outer tubes during the first installation and during maintenance operations to external filters can clog the regulator.

To replace the pressure regulator, disconnect inlet and outlet tubes and undo the 2 screws (a,b) located on the backside of the chiller.

During removal, be careful not to damage the electric wiring or the refrigeration group pipes.

For reassembly, repeat the same operations in reverse order.

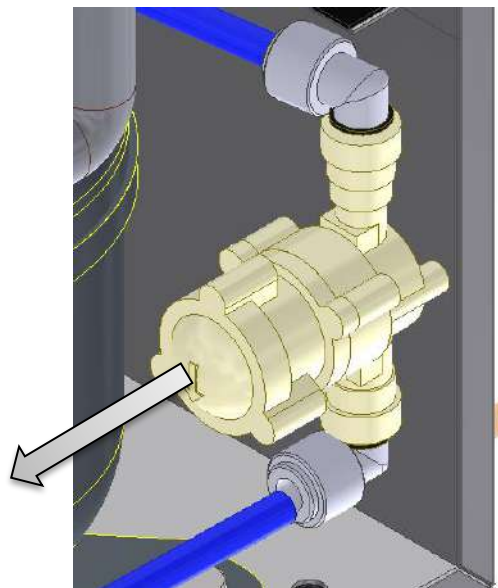
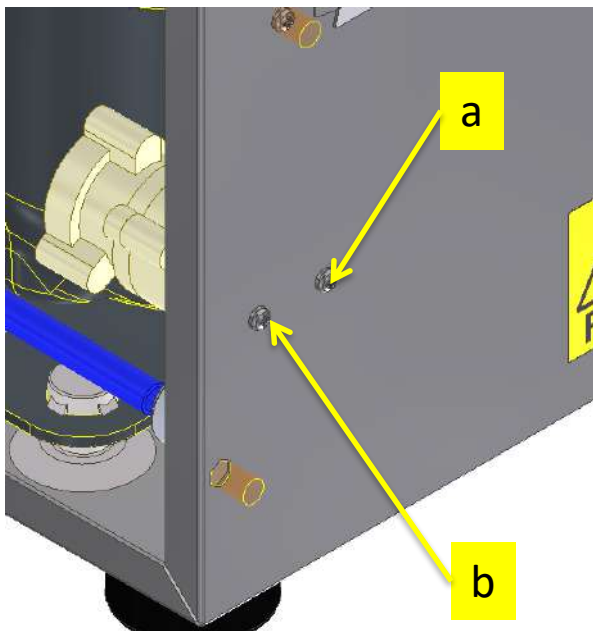

Carbonation Pump

To replace the carbonation pump, disconnect the black wirings from the carbonation control module, loosen the 2 screws (c,d) located on the right side of the pump auxiliary bracket and remove the 2 screws on the left side (a,b); the pump can now be removed for maintenance.

During removal, be careful not to damage the electric wiring or the refrigeration group pipes.

For reassembly, repeat the same operations in reverse order.

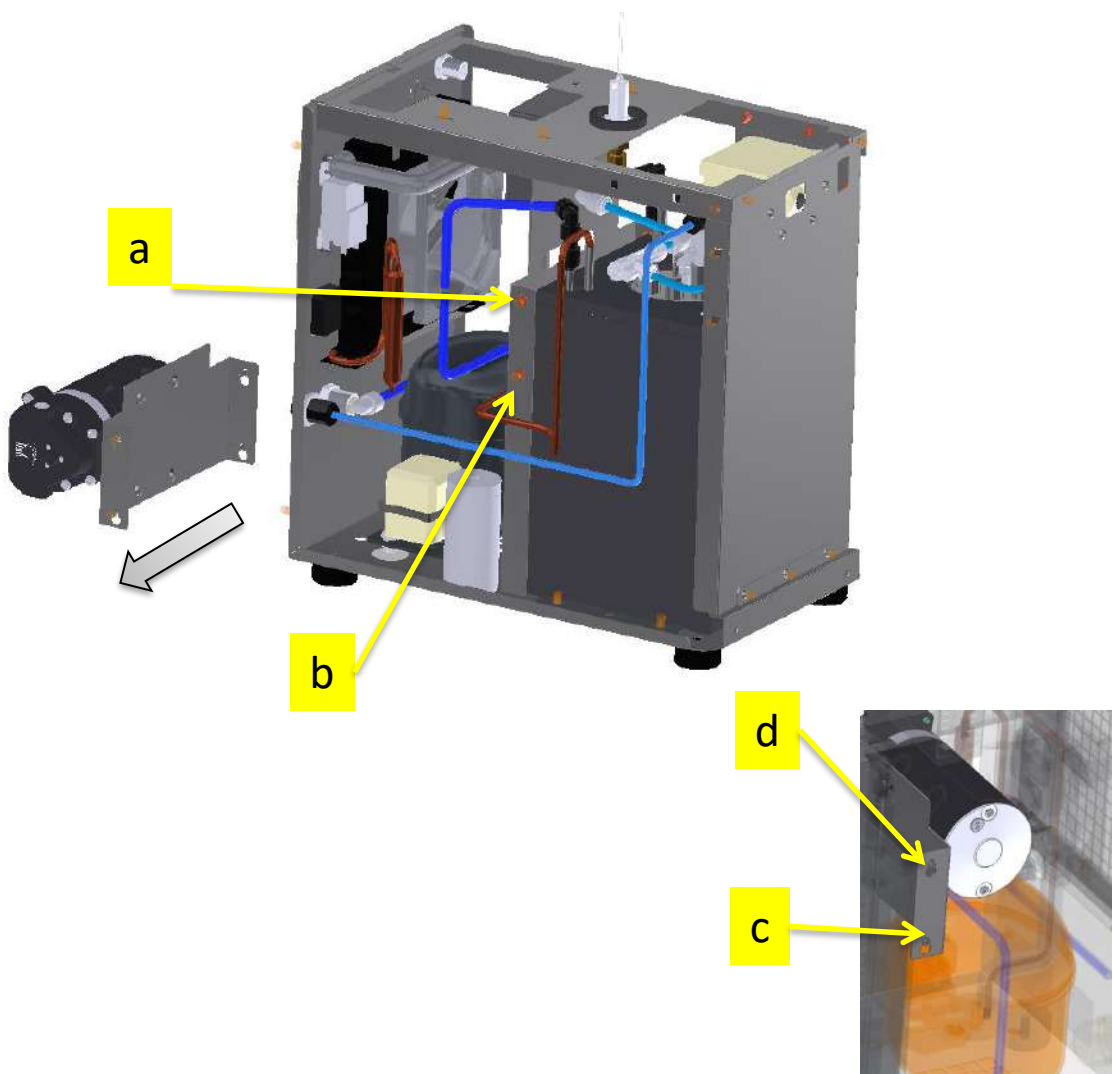

Carbonation Pump Electronic Control Unit

To replace the carbonation pump ECU, disconnect the wirings from the ECU, and undo the screw (a) located on the top side of the bracket; the ECU can be removed for maintenance. During removal, be careful not to damage the electric wiring or the refrigeration group pipes.

For reassembly, repeat the same operations in reverse order paying attention to assembling the electrical connections in the correct order.

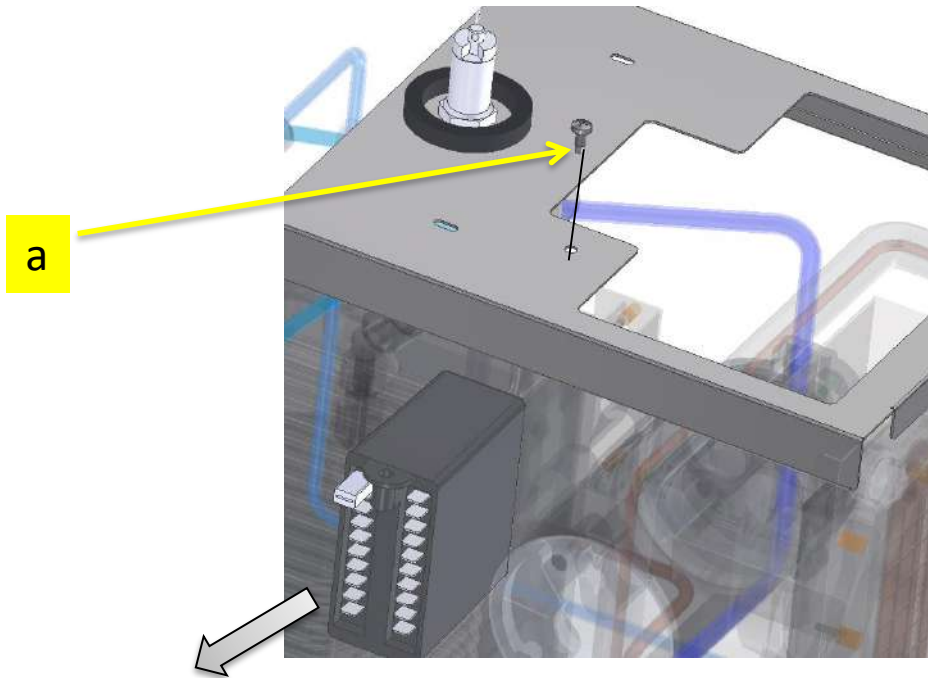

- | | | | |
|--------------------------|--|--------------------------|---------------------------|
| <input type="checkbox"/> | NC | <input type="checkbox"/> | GN/YE Ground connection |
| <input type="checkbox"/> | NC | <input type="checkbox"/> | RD – Carbonator Level mn |
| <input type="checkbox"/> | NC | <input type="checkbox"/> | BK – Carbonator Level max |
| <input type="checkbox"/> | NC | | |
| <input type="checkbox"/> | BK – Carbonation Pump Motor | | |
| <input type="checkbox"/> | BK – Carbonation Pump Motor
/ BU – 230Vac (Piggy back) from main switch | | |
| <input type="checkbox"/> | BU – 230 Vac (Piggy back) to Main Electronic Board | | |
| <input type="checkbox"/> | BN – 230 Vac (Piggy back) to Main Electronic Board | | |
| <input type="checkbox"/> | \ BN – 230Vac (Piggy back) from main switch | | |

Dispense Solenoid Access:

To access the dispense solenoid(s), the solenoid bracket need to be removed. Unscrew the four Phillips screws holding the bracket.

If the dispense solenoid(s) need to be replaced unscrew the two Phillips screws holding the solenoid in place and remove tubing from solenoid body.

During removal, be careful not to damage the electric wirings, refrigeration group pipes and water circuit pipes.

For reassembly, repeat the same operations in reverse order.

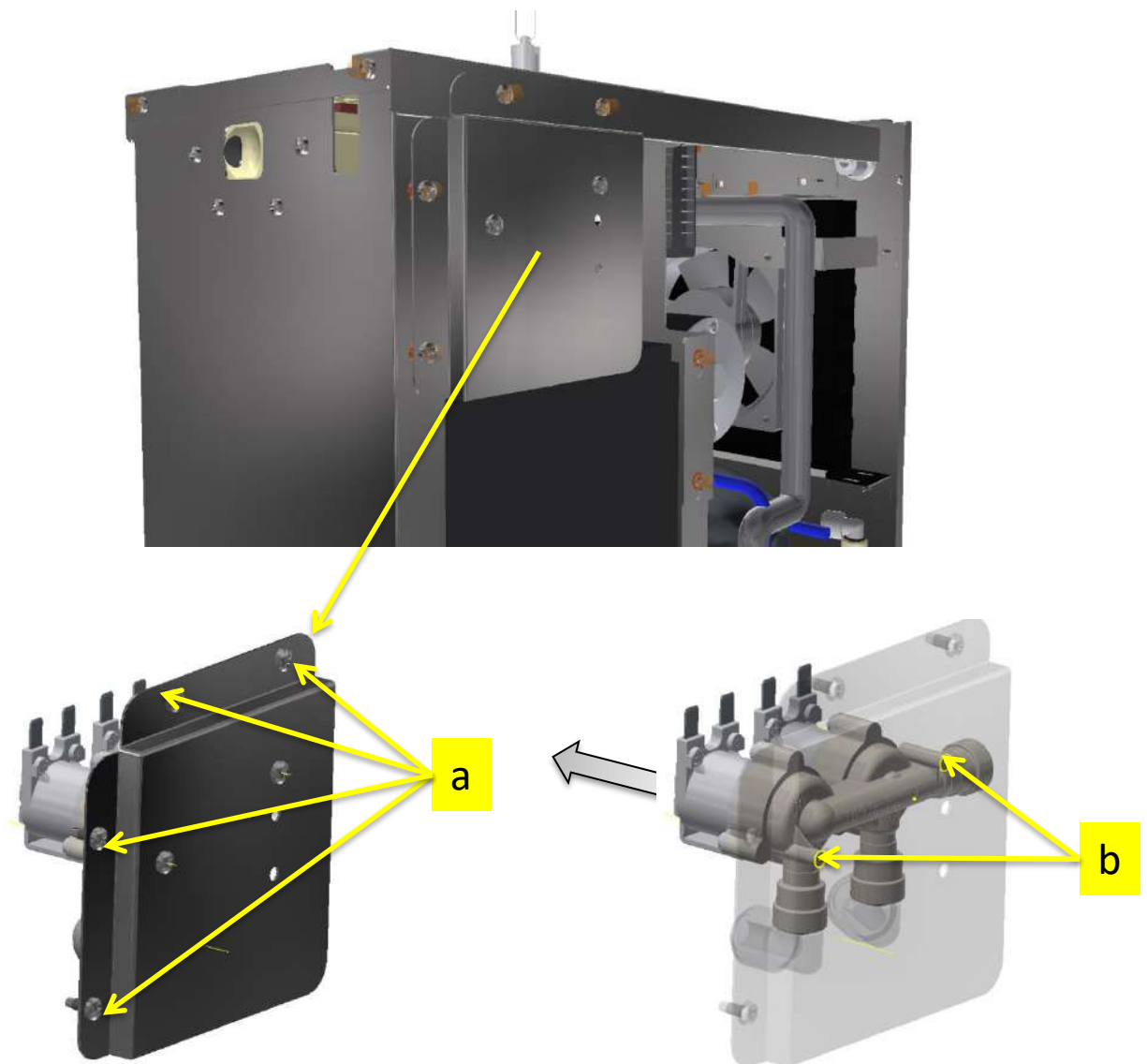

Electronic PCB access

Remove the lid of the chiller.

Remove the PCB enclosure lid by undoing two screws (a,b) this will give access to the PCB.

Carefully remove the electrical connectors, do not apply too much force to avoid damage.

Remove the PCB by undoing the 4 screws (c) located on the PCB itself.

During removal, be careful not to damage the electric wirings, refrigeration group pipes and water circuit pipes.

For reassembly, repeat the same operations in reverse order.

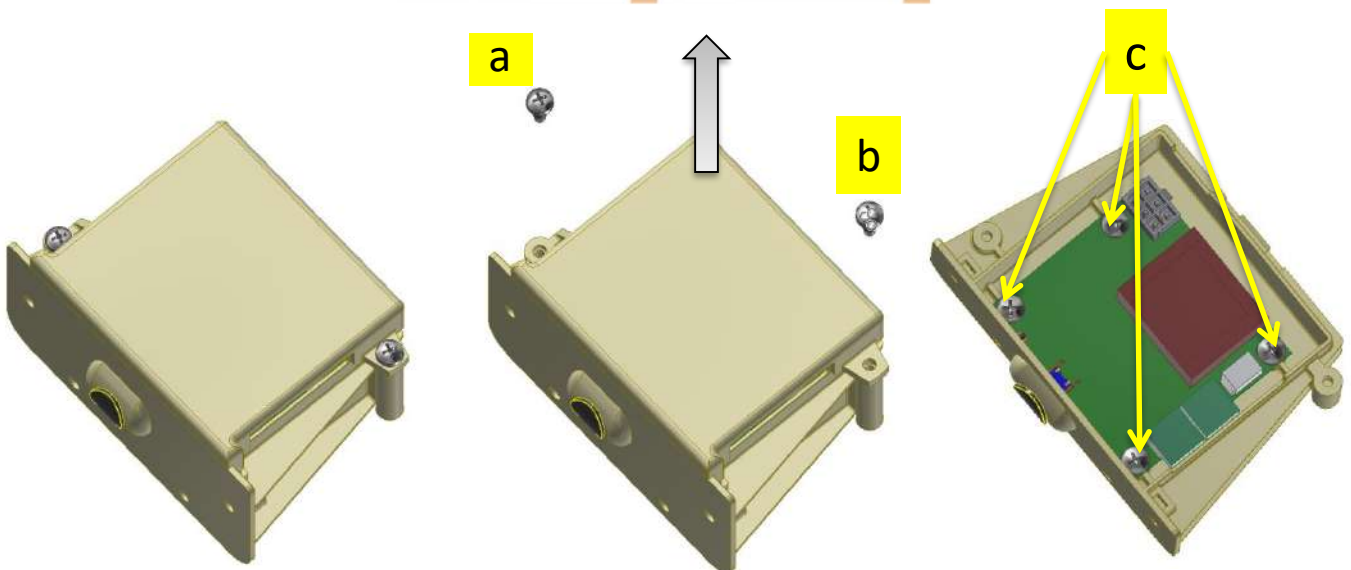
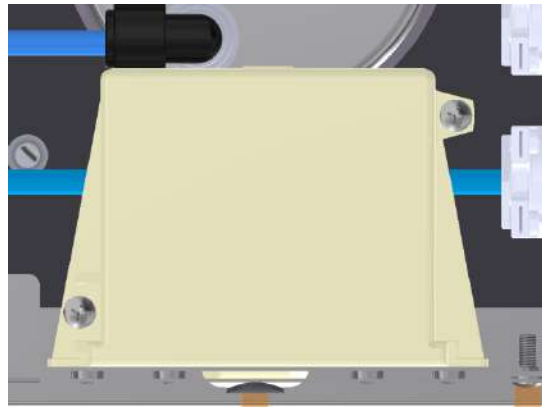

Compressor PCB, PRV valve access for replacement

To access the compressor PCB and/or the PRV the top bracket needs to be removed. To remove the internal top bracket sub-assembly with all components assembled on it (Electronic Control Unit and PRV), remove the 2 screws (a,b) located on the back of the panel and (c,d, e, f) located on the two corners of the top bracket.

During removal, be careful not to damage the electric wirings, refrigeration group pipes and water circuit pipes.

When bracket is removed, you can replace the interested parts.

For reassembly, repeat the same operations in reverse order.

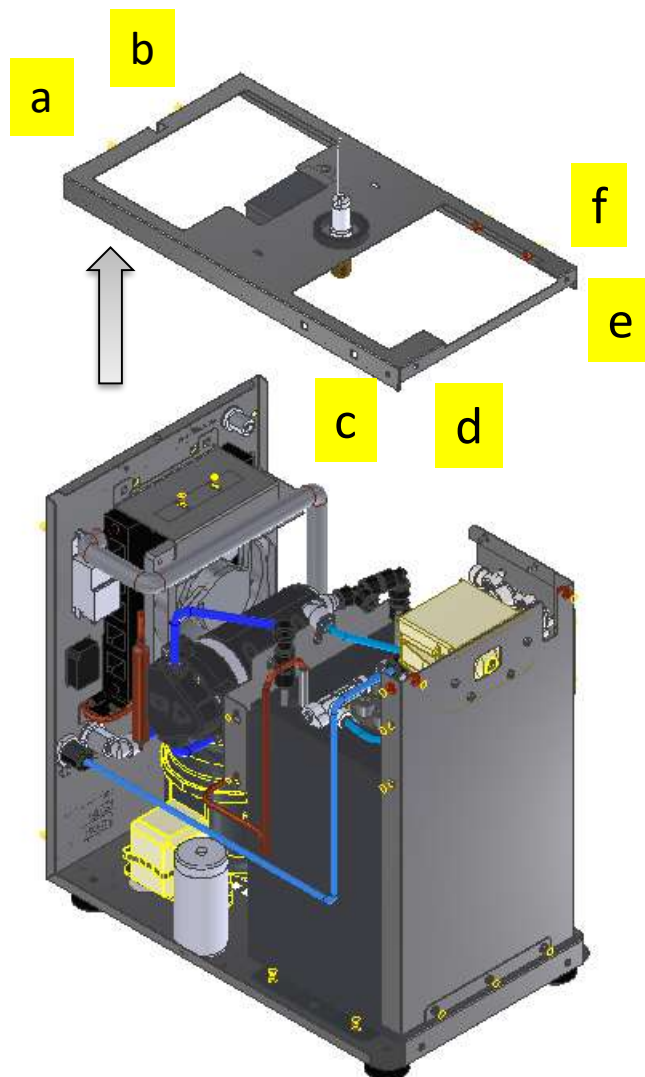

Pressure Relief Valve access and replacement

Please ensure the CO2 is disconnected and purged from the machine.

To remove the PRV, firstly remove the tubing from hydraulic fitting and afterwards undo the fitting (a) from the PRV.

Carefully unscrew the PRV bolt (b) from the bracket and repair or replace the valve.

During removal, be careful not to damage the electric wirings, refrigeration group pipes and water circuit pipes.

For reassembly, repeat the same operations in reverse order.

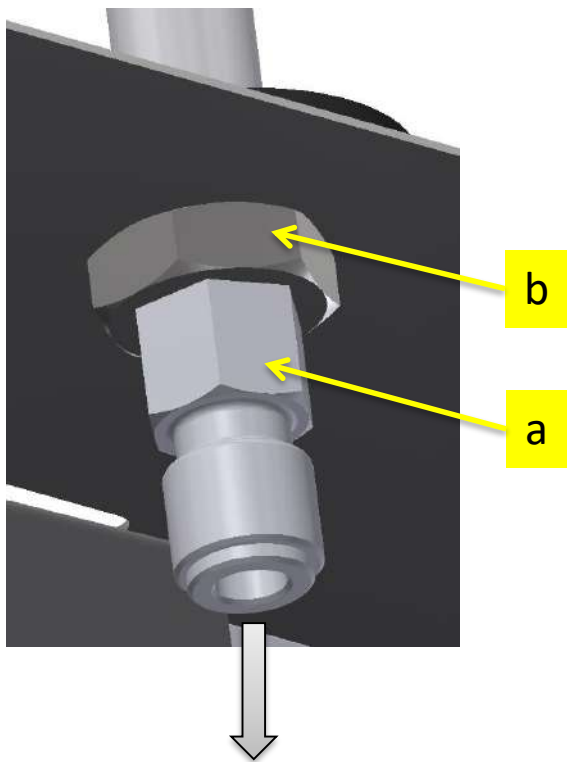

Pressure Relief Valve cleaning and replacement

In case of leakage from PRV, the movable plunger can be easily remove for check and cleaning.

Please ensure the CO2 is disconnected and purged from the machine.

This can be done without removal of the outer lid; simply keep the PRV with a pliers simply hold the steel valve body (a) in place while at the same time unscrew the plastic body of the PRV by acting on the cylindrical part (b).

During removal, be careful not to damage the plunger and threads.

Inspect for damage and/or residuals on the sealing, C. Replace the plunger if needed.

For reassembly, repeat the same operations in reverse order.

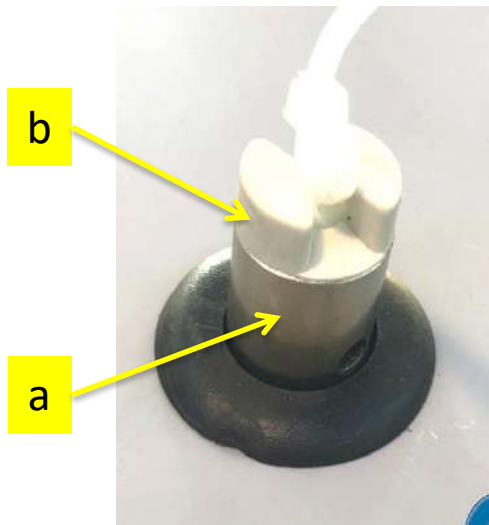

Carbonator NRV cleaning and replacement (CO2 in cold still water)

Sporadically, dust or iron particles may be present in the pipes or coils of the chiller or may come from the outer tubes during the first installation or during maintenance operations to external filters. In the case of leakage from NRV (CO2 in cold still water), the NRV should be removed checked and cleaned.

Please ensure the CO2 is disconnected and purged from the machine.

This can be done removing the internal top bracket sub-assembly with all components, as described previously, giving access to the carbonator.

Identify the two NRV; the CO2 NRV (a) is the one directly connected to the CO2 inlet; the water inlet NRV (b) is the one connected to the alublock coil.

Undo the hydraulic connection on the inlet of the NRV (b) and with a spanner remove the body of NRV.

During removal, be careful not to damage the plunger and threads and note the assembly orientation of the internal components.

Inspect for damage and/or residuals on the plunger spring (c) and on the seal (d). Replace the plunger if needed.

For reassembly, repeat the same operations in reverse order.

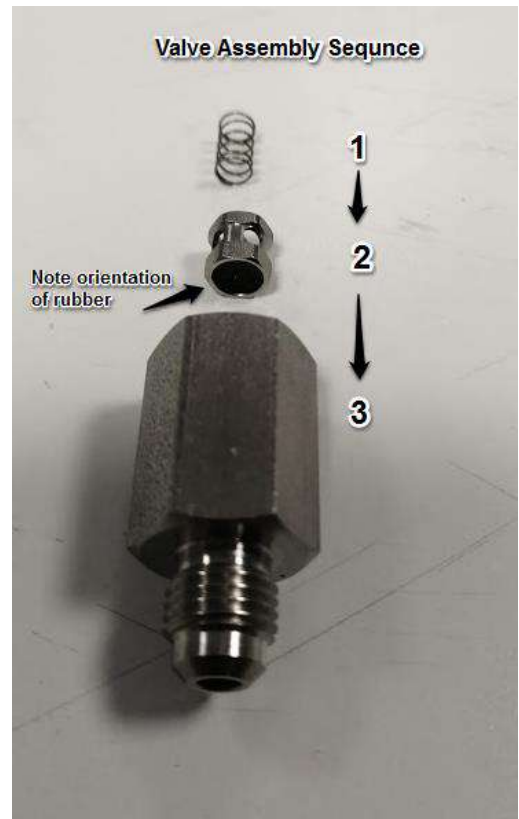
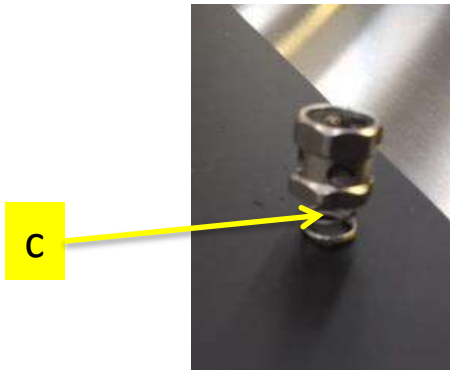
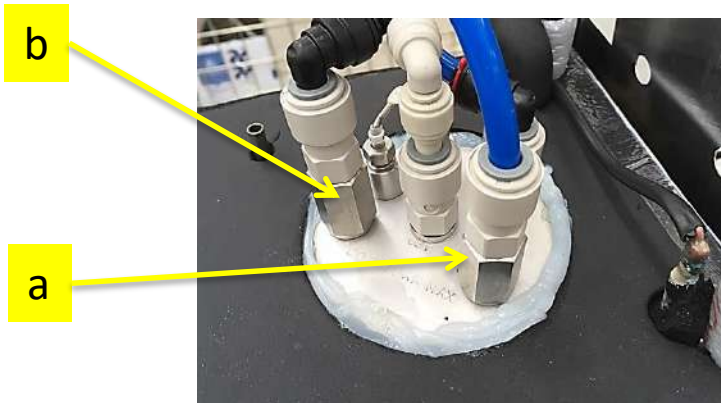

7. TROUBLESHOOTING - DIAGNOSTIC GUIDE:

ISSUE	PROBABLE CAUSE	SOLUTION
The compressor will not start	Power failure	Check that there is voltage in the plug
	Thermostat in the off position, or set to the minimum	Check wirings and adjust the thermostat position
	Faulty thermostat	Check wirings replace the thermostat
	The over-load protection of the compressor is faulty	Wait for compressor cool down and replace it
	The starting relay is faulty	Check wiring replace the faulty component
	The starting capacitor is faulty	Check wiring replace the faulty component
	The compressor is faulty	Check wiring replace the faulty component
The water is cold but the appliance is operating excessively or non-stop	Poor ventilation	Place the appliance away from the wall
	The condenser is dirty or covered	Clean the condenser or free it from obstructions
	The thermostat is on maximum cold position	Adjust thermostat knob in the middle rotational range
	Ambient temperature is higher than 32°C	It is normal that the appliance works at a continuously high room temperature
The compressor works continuously, but the water is not cold	Gas leak from the cooling system	Contact a specialized technician (refrigerator repairman) or Marco Beverage Systems
	The compressor is faulty	Check wirings and voltage on compressor terminals and replace the faulty component if needed.
Too much noise coming from the equipment, but it is working normally	The machine is not perfectly horizontal	Level the appliance using the adjustable feet
	Hoses and wirings are in contact with housing some parts inside the equipment and generate noise and vibrations.	Check and reposition hoses and wirings, making sure they do not touch any other parts.
Cold water comes out slowly or not at all	Water inlet supply shutoff valve closed or faulty electrovalves closed, water filter fouled/clogged.	Open water inlet supply line shutoff valve, check electrovalves and anti-flooding device replace electrovalves ; replace filter or cartridge.
	Low pressure of the inlet net water	Take steps to increase the net pressure (e.g. booster pump)
	The thermostat is out of tolerance range or defective.	Waiting for ice melting down. Replace Alublock thermostat.

ISSUE	PROBABLE CAUSE	SOLUTION
Too low CO ₂ volume	CO ₂ pressure too low	Restore correct CO ₂ pressure (typically about 4 bar / 60 psi)
	CO ₂ cylinder empty	Replace CO ₂ cylinder
	Water temperature too high because cooling capacity is exceeded by over drawing	See refrigeration/equipment specifications vs. volume requirements and reduce amount of glasses taken per given time of install higher volume unit.
	Air trapped inside the carbonator	Open carbonator vent check valve, pulling ring, until water streams out.
CO ₂ only flows out from faucet	Carbonator Electrode connection to wiring harness defective, loose electrical connection and/or open circuit	Tighten connection, repair carbonator wiring harness connection and check electrode connection at E.C.U.
	The carbonation pump turns continuously	No water is entering or the water filter is blocked or Hoses and pipe fittings into the carbonator are obstructed. Disassemble and clean it.
	Check valve on carbonator water inlet failed open	Verify correct behavior of the non-return (check valve) assembled on the carbonator water inlet.
	Inoperable water pump/ motor.	Check for proper line voltage on component terminals. Replace water pump/ motor if defective.
	Electronic Control Unit (E.C.U.) defective.	Replace E.C.U. assembly.
	E.C.U. in timeout (> 240" continuous operation)	Reset Timeout protection switching off equipment and waiting 60" before repower it.
Short cycling of water pump motor	Carbonator Electrode connection to wiring harness defective or reversed.	Repair carbonator wiring harness connection and check electrode connection at E.C.U.
Continuous dripping from the outlets	Few drops, mainly after soda dispensing is normal. If dripping is continuous faucet or internal electrovalve could be dirty.	Disassemble the internal solenoid valve and clean it.
Still water comes out carbonated	Internal check valve could be dirty.	Disassemble check valve and clean it. Replace if needed.

8. WIRING DIAGRAM:

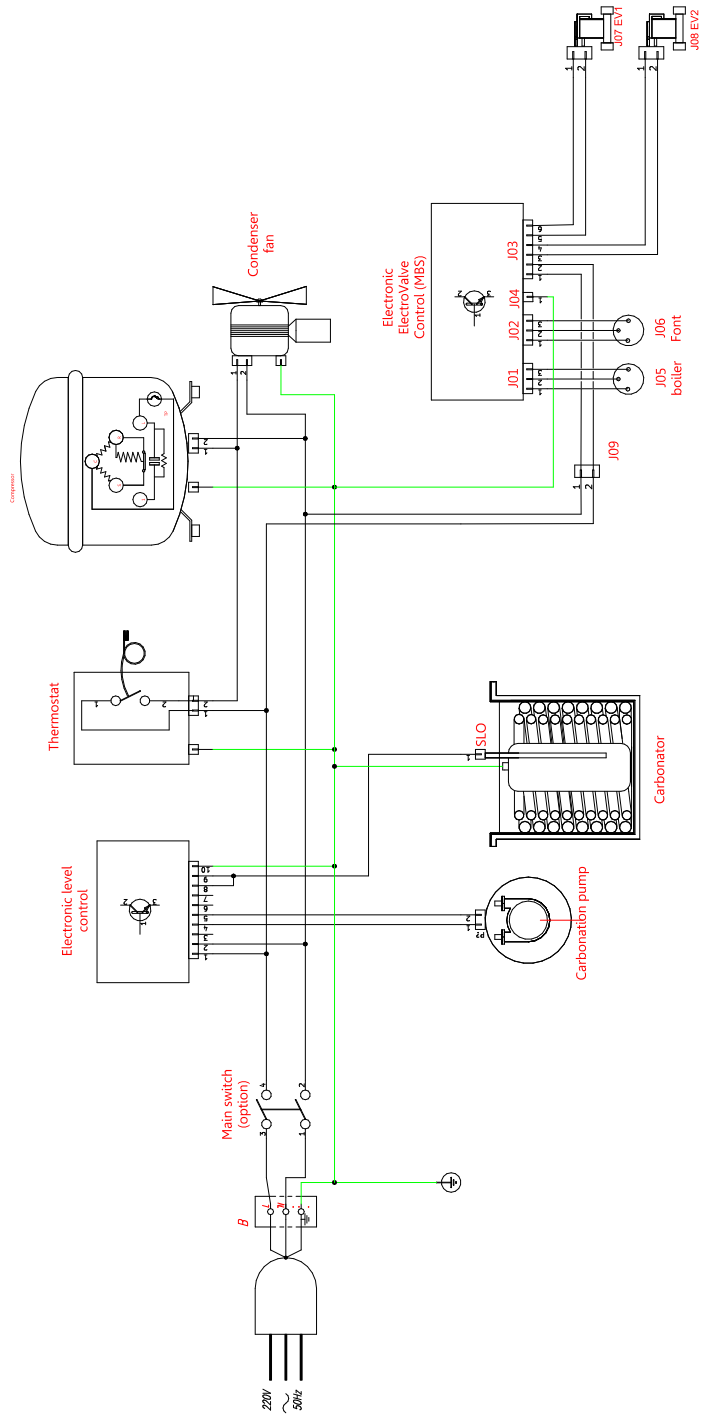
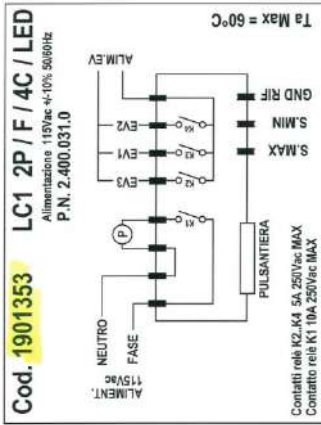
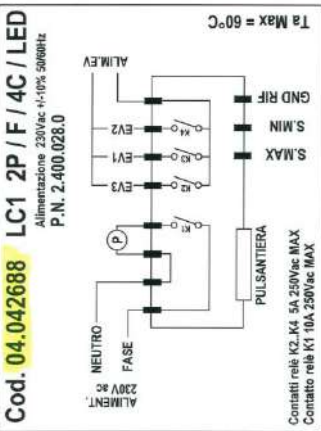

Functional Hydraulic Schematic

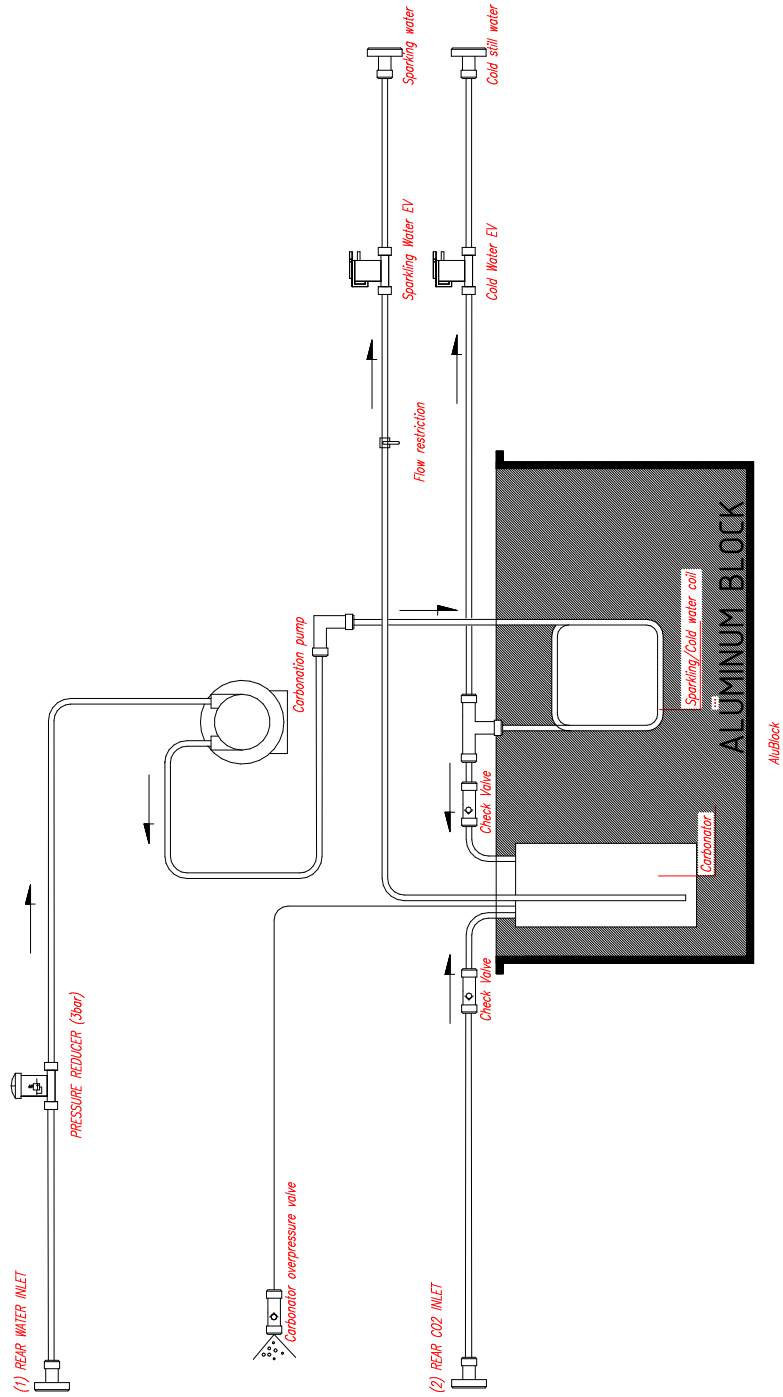

10. INSTALLATION DIAGRAM:

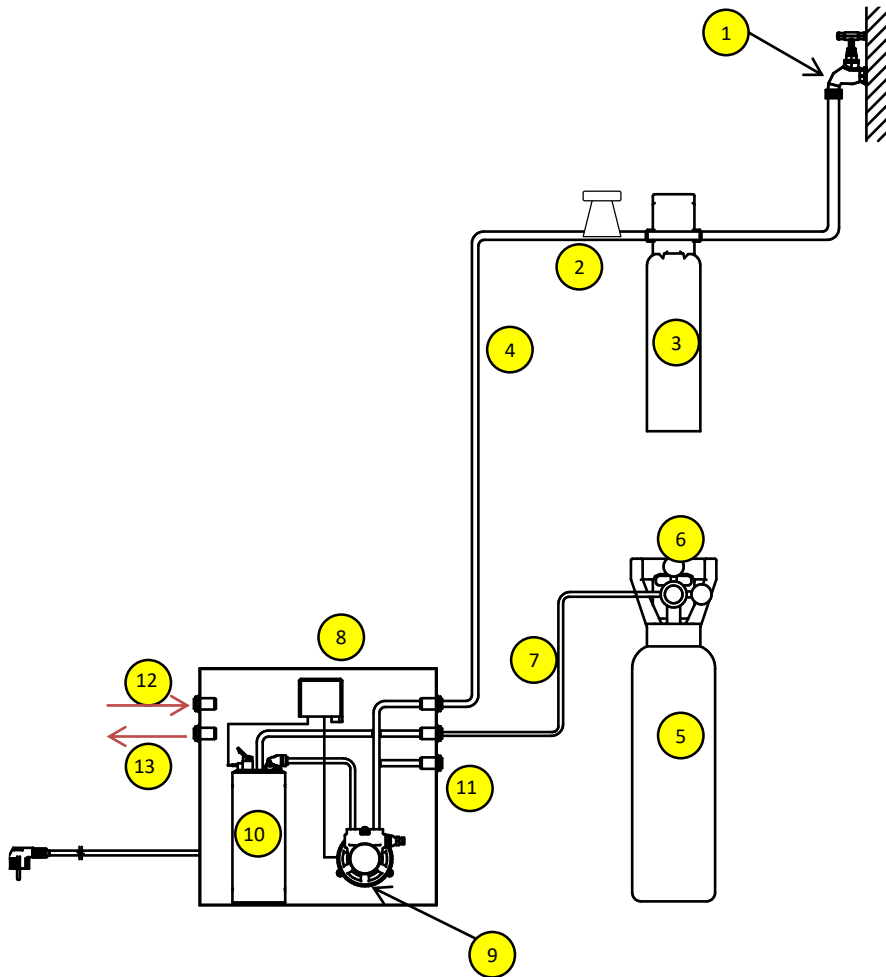

1. REAR WATER INLET
2. STOP VALVE H₂O
3. FILTER H₂O
4. WATER INLET LINE
5. CO₂ CYLINDER
6. CO₂ PRESSURE REDUCER
7. CO₂ INLET TUBING
8. CARBONATION CONTROL UNIT
9. CARBONATION PUMP
10. CARBONATOR
11. TOP SPARKLING WATER OUT
12. TOP COLD STILL WATER OUT
13. TOP COLD STILL WATER OUT

11.2 Outer frame:

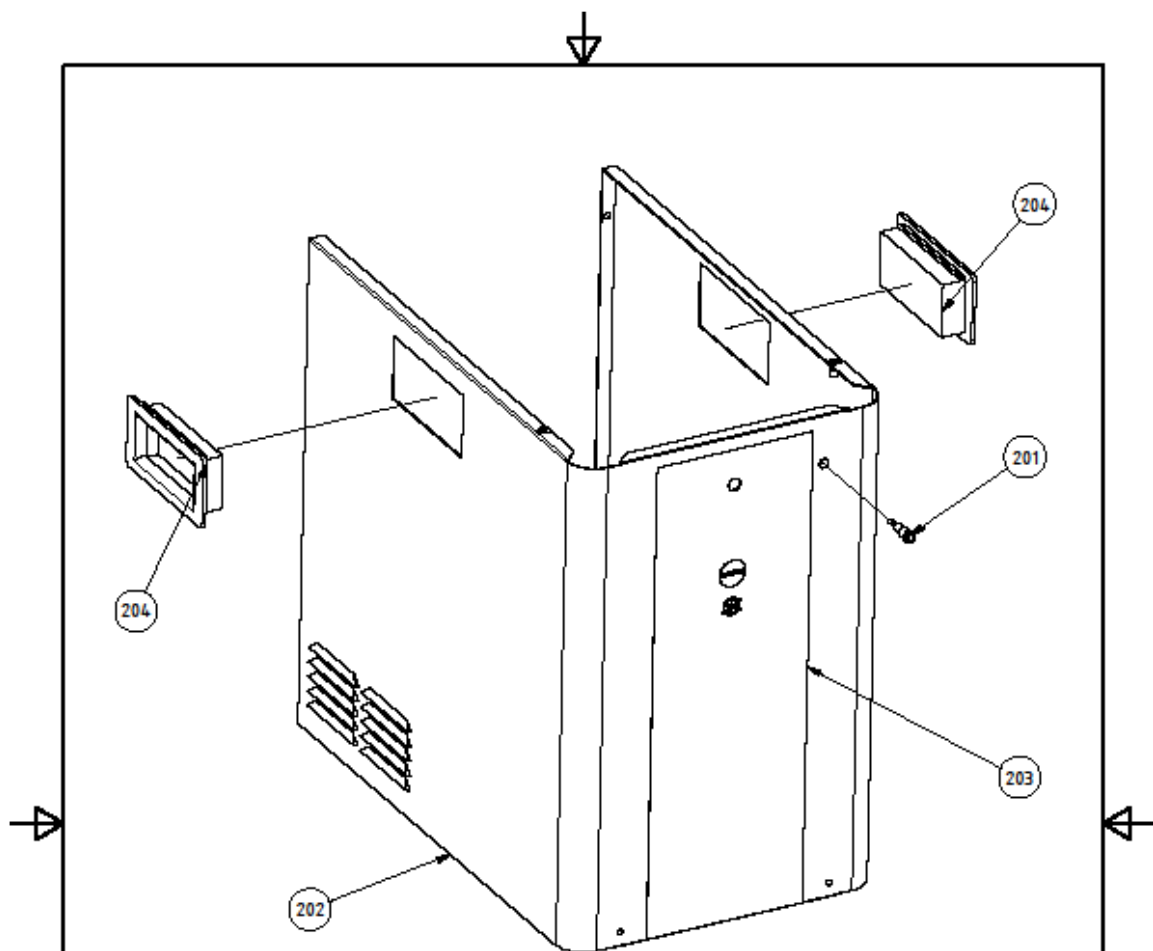

PART LIST				
Ref #	Part Description	230Vac version PART NUMBER	115Vac version PART NUMBER	NOTES
201	GREEN LED WITH HARNESS	04-042100	04-042100	
202	OUTER FRAME	24-N500992	24-N500992	
203	FRONT LABEL MBS	04-042630	04-042630	
204	HANDLE MBS	04-042746	04-042746	

	Date		Name		Treatment	Scale
	Material		Description			
	Drawn	02/05/2019	U.T.		OUTER FRAME ASSEMBLY	
	Checked					
	Standard					
Tolleranza generali				UNI EN 22768-mK	24-N500992	1
						A4
State	Changes	Date	Name			

11.3 Top bracket:

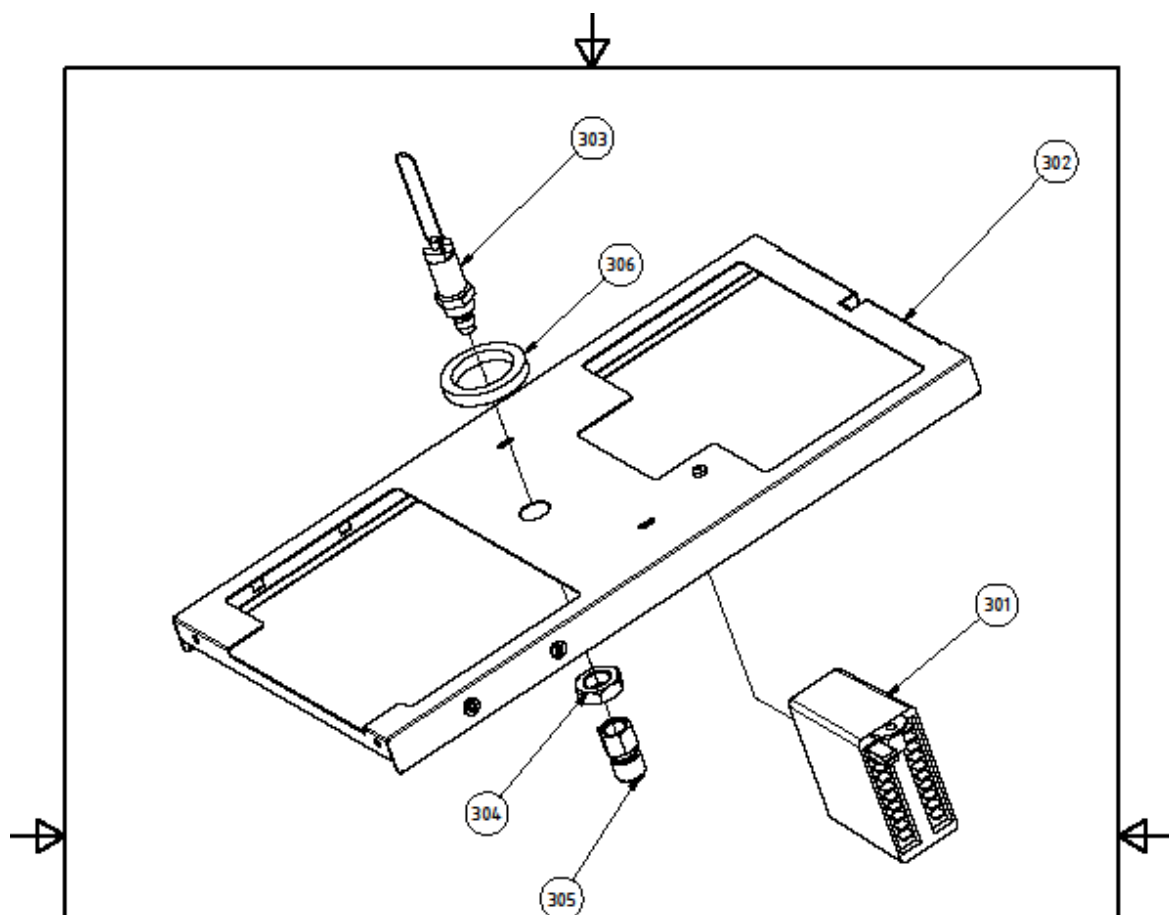

PART LIST				
Ref #	Part Description	230Vac version PART NUMBER	115Vac version PART NUMBER	NOTES
301	CARBONATION ELECTRONIC CONTROL UNIT	04-042688	19-1901353	SW VERSION ONLY
302	TOP BRACKET	24-N5009941	24-N5009941	
303	CARBONATOR PRV	10-110342PRV	10-110342PRV	SW VERSION ONLY
304	CARBONATOR PRV NUT	24-N90753	24-N90753	SW VERSION ONLY
305	CARBONATOR PRV 5/16 OD X THREAD 7/16 20F	11-110017	11-110017	SW VERSION ONLY
306	PRV RING GROMMET	04-042680	04-042680	SW VERSION ONLY



		Treatment		Scale	
		Material			
		Description			
		TOP BRACKET ASSEMBLY			
		Date		Name	
Drawn		02/05/2019		U.T.	
Checked					
Standard					
Tolleranza generali					
UNI EN 22768-mK					
				24-N5009941	
				1	
				A4	
State	Changes	Date	Name		

11.4 Front electronic bracket:

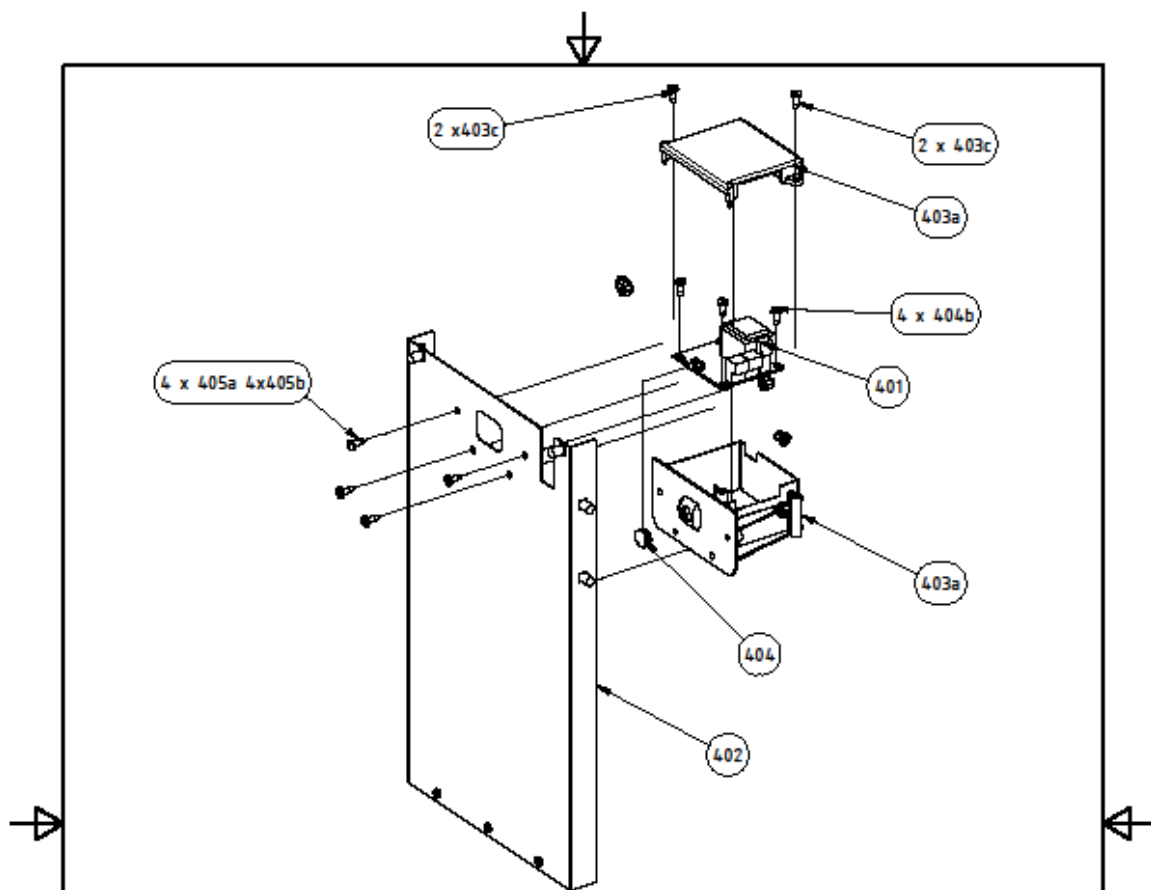

PART LIST				
Ref #	Part Description	230Vac version PART NUMBER	115Vac version PART NUMBER	NOTES
401	CARBONATION ELECTRONIC CONTROL UNIT	To be defined	To be defined	
402	FRONT ELECTRONIC BRACKET	24-N500994	24-N500994	
403a	ELECTRONIC PLASTIC CASING	04-042821	04-042821	
403b	PCB SCREWS	24-N90753	24-N90753	
403c	CASING SCREWS	11-110017	11-110017	
404	PUSHBUTTON	To be defined	To be defined	
405a	NUT M4 SS UNI5588	01-0103500	01-0103500	
405b	BOLT SS M4 X 12	24-N1947	24-N1947	

	Treatment		Scale
	Material		
	Date	Name	Description
	Drawn 02/05/2019	U.T.	FRONT ELECTRONIC BRACKET ASSEMBLY
	Checked		
Standard			
Tolleranza generali UNI EN 22768-mK			24-N500994
1			
A4			
State	Changes	Date	Name

11.5 Pump and Electrovalve brackets:

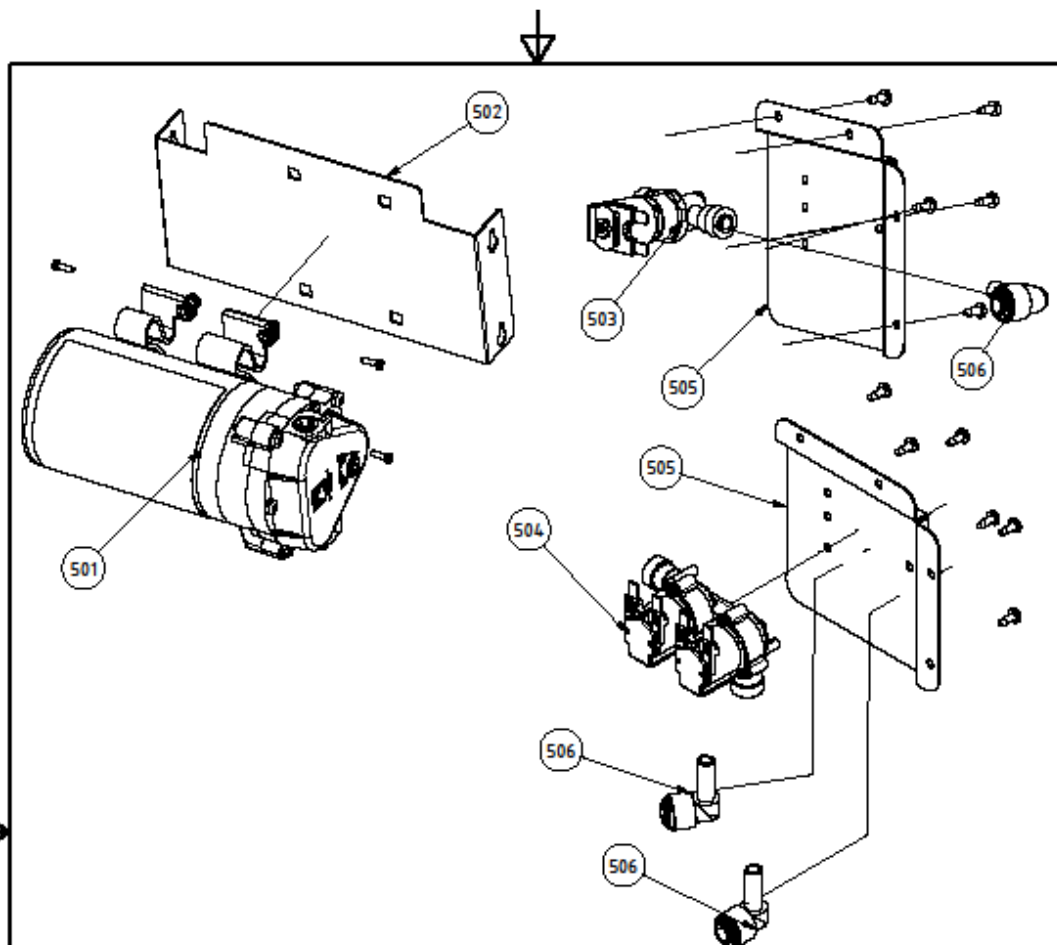

PART LIST				
Ref #	Part Description	230Vac version PART NUMBER	115Vac version PART NUMBER	NOTES
501	BOOSTER MEMBRANE PUMP	06 PEM516JG	06 PEM516JG115	
502	PUMP BRACKET	24-N501215	24-N501215	
503	SINGLE EV 1xIN JG 1/4" 1xOUT JG 1/4	04-042530	04-042714	COLD STILL VERSION ONLY
504	DOUBLE EV 2xIN JG 1/4" 1xOUT JG 1/4	04-042740	B04-042715	SPARKLING VERSION ONLY
505	ELECTROVALVE BRACKET	24-501216	24-501216	
506	STEM ELBOW 5/16 TO 1/4 OD	11-110238	11-110238	

	Date		Name		Treatment	Scale
	Drawn	02/05/2019	U.T.		Material	
	Checked				Description	
	Standard					
Tolleranza generali				24-N501215		1
UNI EN 22768-mK						A4
State	Changes	Date	Name			

11.6 Base :

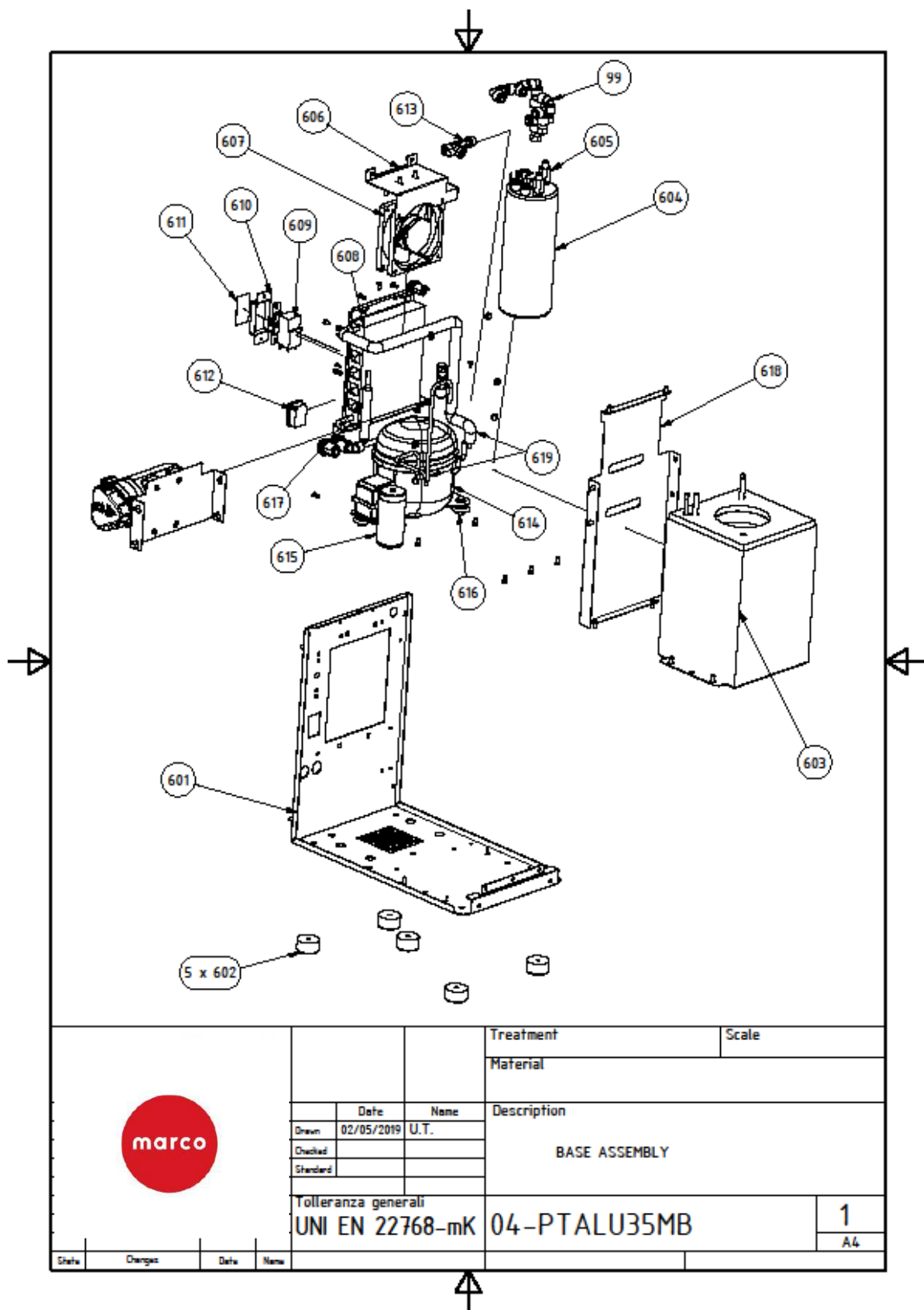

			Treatment	Scale
			Material	
	Date	Name	Description	
	Drawn	02/05/2019 U.T.	BASE ASSEMBLY	
	Checked			
Standard				
Tolleranza generali		UNI EN 22768-mK 04-PTALU35MB		1
State	Changes	Date	Name	A4

CABLES AND HARNESSSES

620

UK

115Vac

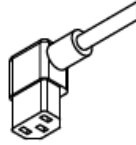

IEC 60320, C-13

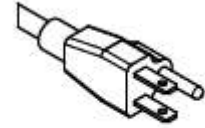
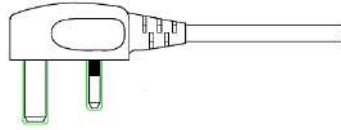

NEMA 5-15P

621

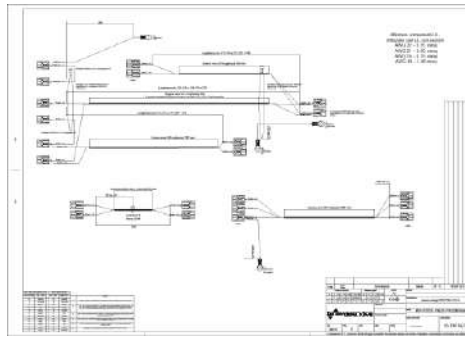

622

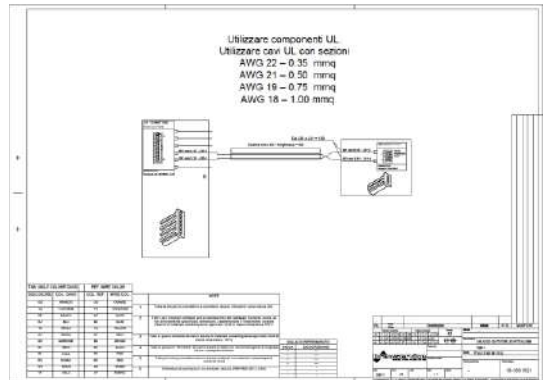
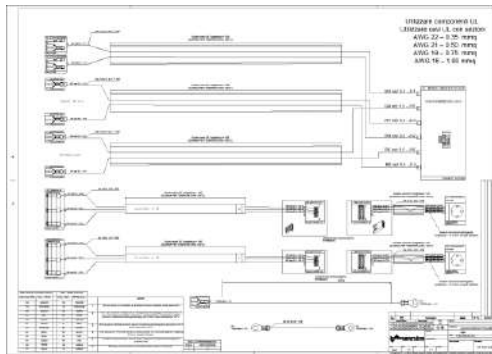

623

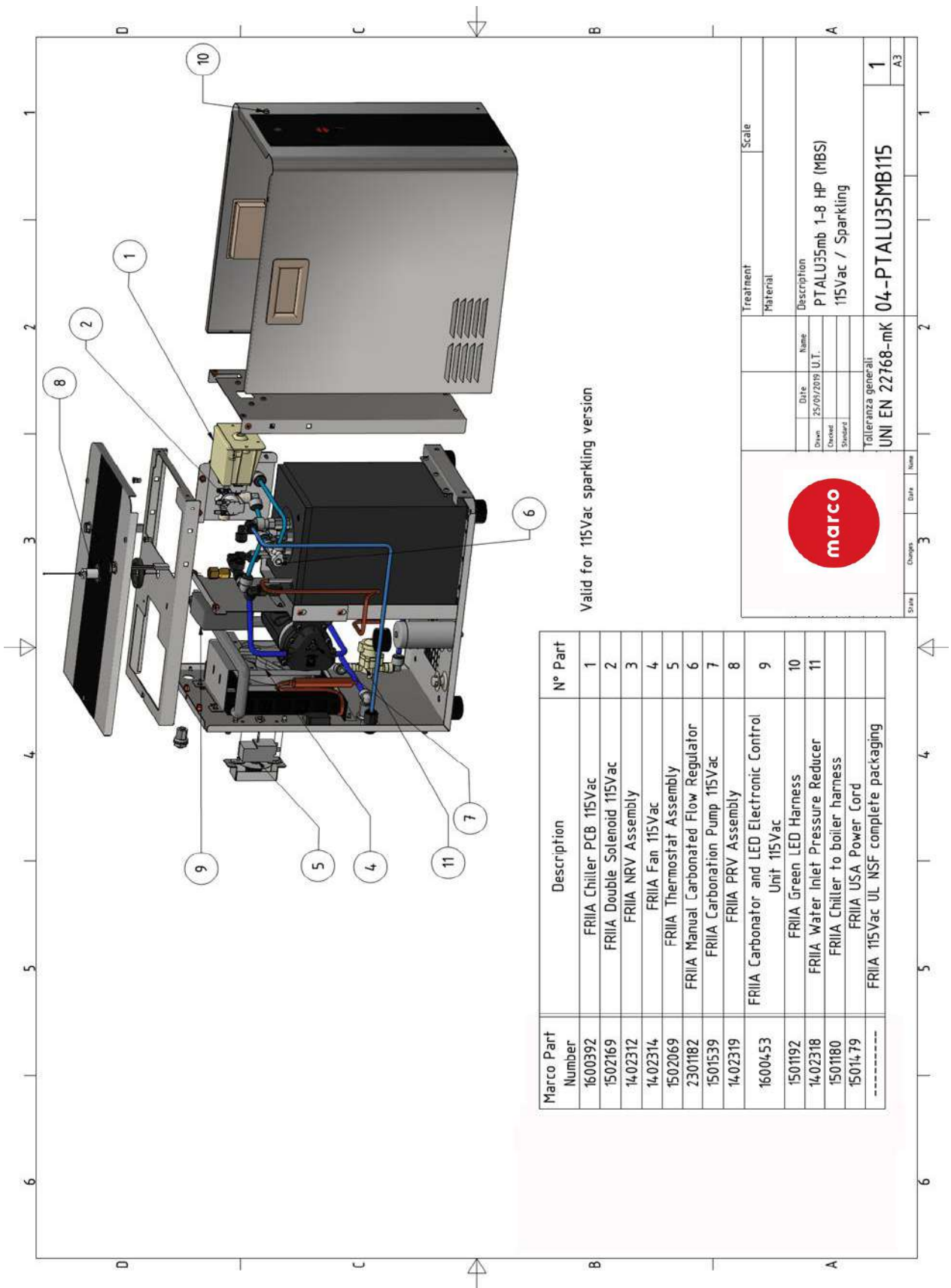

Valid for 115Vac sparkling version

Marco Part Number	Description	N° Part
1600392	FRIIA Chiller PCB 115Vac	1
1502169	FRIIA Double Solenoid 115Vac	2
1402312	FRIIA NRV Assembly	3
1402314	FRIIA Fan 115Vac	4
1502069	FRIIA Thermostat Assembly	5
2301182	FRIIA Manual Carbonated Flow Regulator	6
1501539	FRIIA Carbonation Pump 115Vac	7
1402319	FRIIA PRV Assembly	8
1600453	FRIIA Carbonator and LED Electronic Control Unit 115Vac	9
1501192	FRIIA Green LED Harness	10
1402318	FRIIA Water Inlet Pressure Reducer	11
1501180	FRIIA Chiller to boiler harness	
1501479	FRIIA USA Power Cord	
-----	FRIIA 115Vac UL NSF complete packaging	

Treatment		Scale	
Material			
Date	Name	Description	
Drawn 25/07/2019 U.T.		PTALU35mb 1-8 HP (MBS)	
Checked		115Vac / Sparkling	
Standard			
Tolleranza generali			
UNI EN 22768-mK		04-PTALU35MB115	
1	A3		

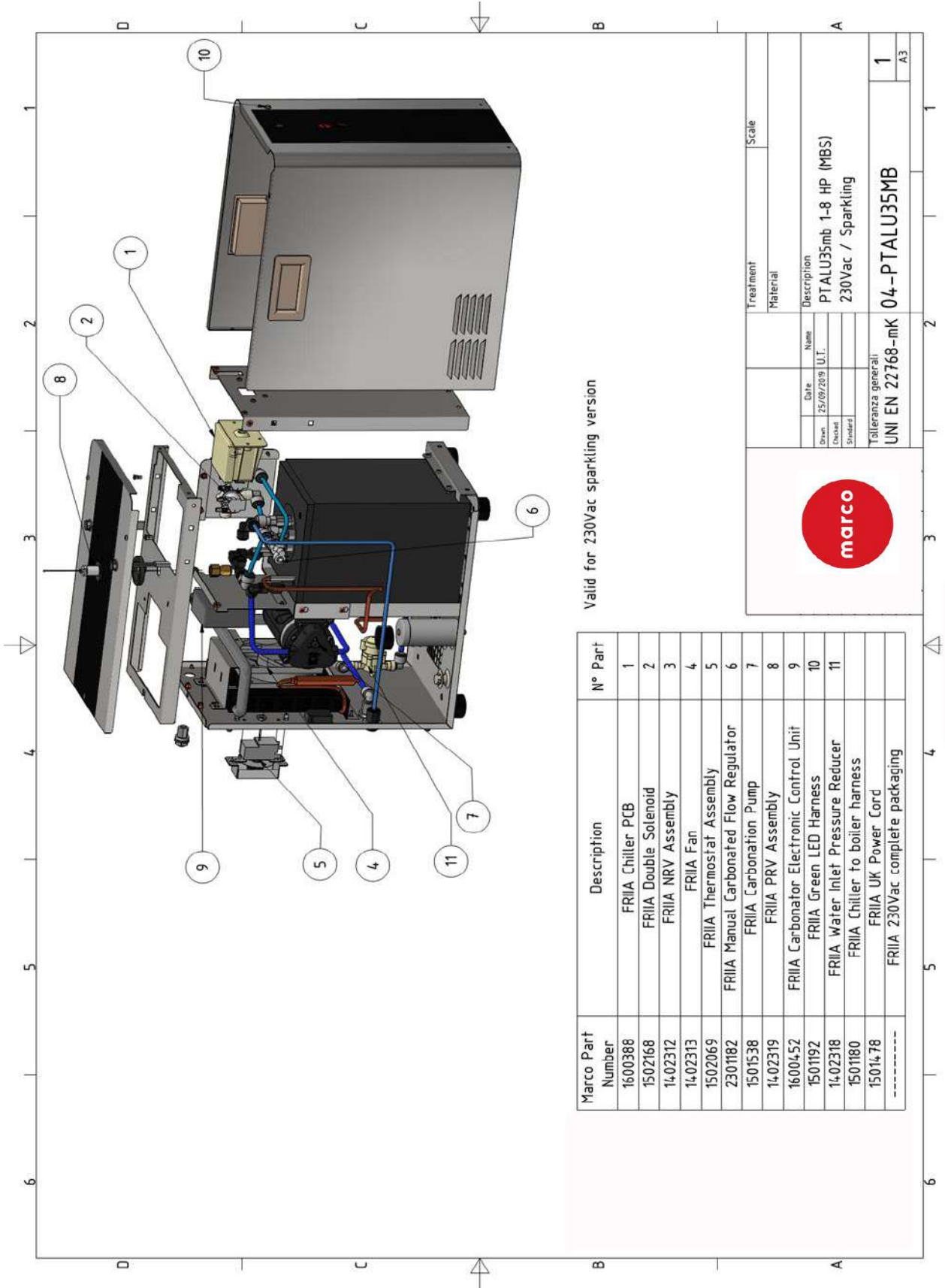

Valid for 230Vac sparkling version

Marco Part Number	Description	N° Part
1600388	FRIIA Chiller PCB	1
1502168	FRIIA Double Solenoid	2
14.02312	FRIIA NRV Assembly	3
14.02313	FRIIA Fan	4
1502069	FRIIA Thermostat Assembly	5
2301182	FRIIA Manual Carbonated Flow Regulator	6
1501538	FRIIA Carbonation Pump	7
14.02319	FRIIA PRV Assembly	8
1600452	FRIIA Carbonator Electronic Control Unit	9
1501192	FRIIA Green LED Harness	10
14.02318	FRIIA Water Inlet Pressure Reducer	11
1501180	FRIIA Chiller to boiler harness	
1501478	FRIIA UK Power Cord	
-----	FRIIA 230Vac complete packaging	

Treatment		Scale	
Material			
Date	Name	Description	
Drawn: 25/09/2019	D.T.	PTALU35mb 1-8 HP (MBS)	
Checked		230Vac / Sparkling	
Standard			
Tolleranza generali			
UNI EN 22768-mK		04-PTALU35MB	
		1	
		A3	

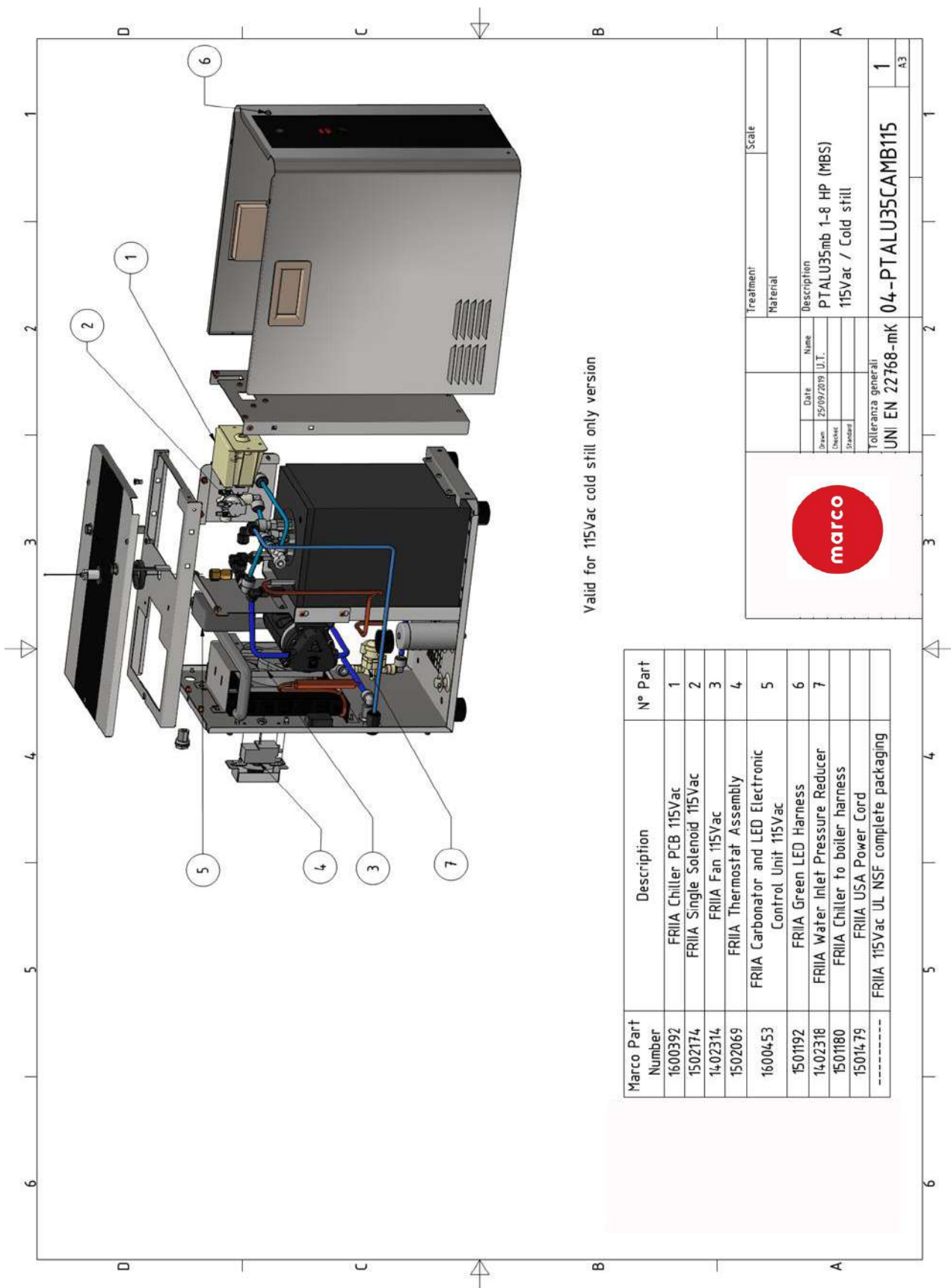

Valid for 115Vac cold still only version

Marco Part Number	Description	N° Part
1600392	FRIIA Chiller PCB 115Vac	1
1502174	FRIIA Single Solenoid 115Vac	2
14-02314	FRIIA Fan 115Vac	3
1502069	FRIIA Thermostat Assembly	4
1600453	FRIIA Carbonator and LED Electronic Control Unit 115Vac	5
1501192	FRIIA Green LED Harness	6
14-02318	FRIIA Water Inlet Pressure Reducer	7
1501180	FRIIA Chiller to boiler harness	
1501479	FRIIA USA Power Cord	
-----	FRIIA 115Vac UL NSF complete packaging	

Treatment		Scale	
Material			
Date	Name	Description	
Drawn	25/09/2019	PTALU35mb 1-8 HP (MBS)	
Checked		115Vac / Cold still	
Standard			
Tolleranza generali			
UNI EN 22768-mk		04-PTALU35CAMB115	
		1	
		A3	

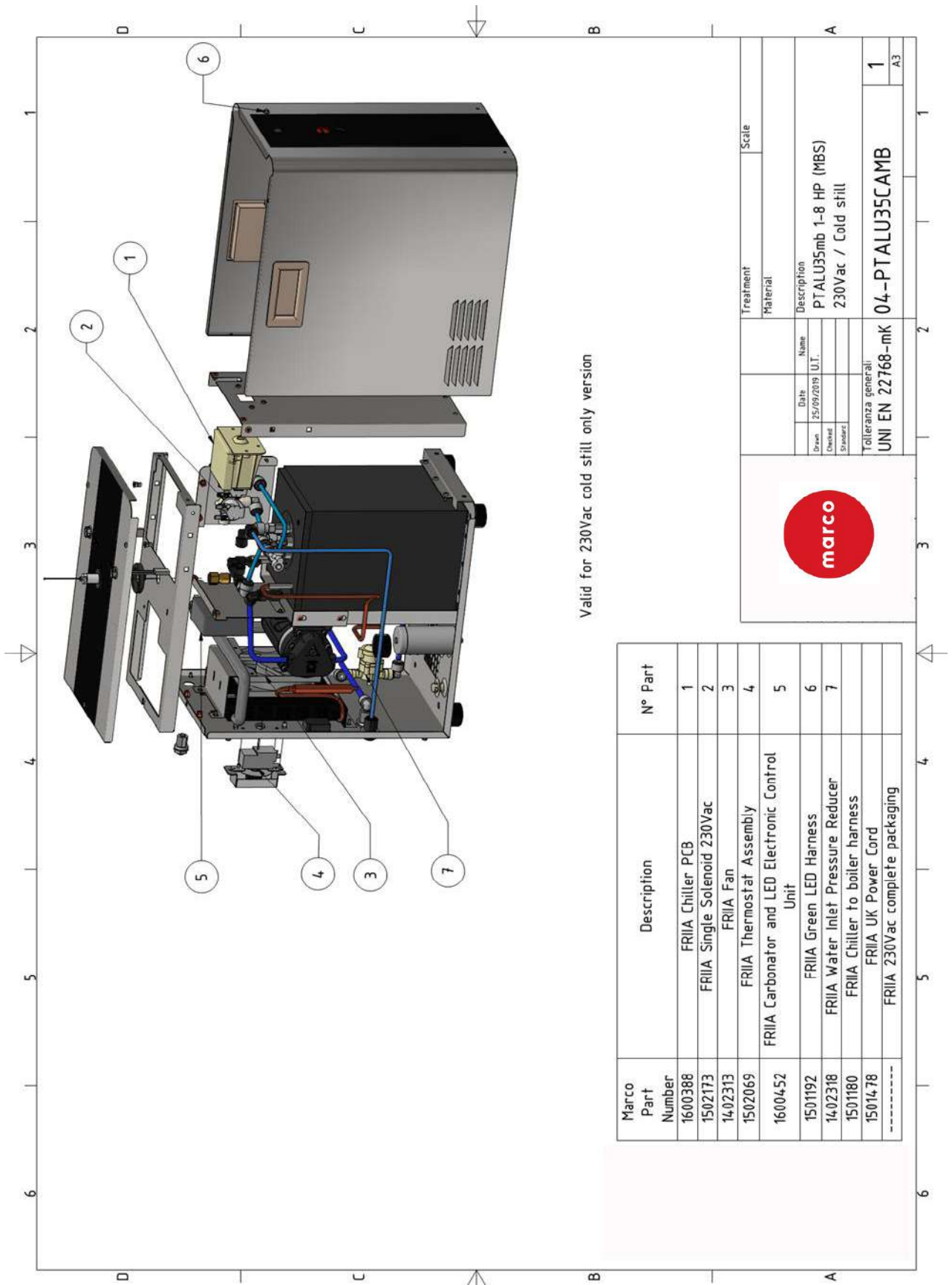

Valid for 230Vac cold still only version

Marco Part Number	Description	N° Part
1600388	FRIIA Chiller PCB	1
1502173	FRIIA Single Solenoid 230Vac	2
14-02313	FRIIA Fan	3
1502069	FRIIA Thermostat Assembly	4
1600452	FRIIA Carbonator and LED Electronic Control Unit	5
1501192	FRIIA Green LED Harness	6
14-02318	FRIIA Water Inlet Pressure Reducer	7
1501180	FRIIA Chiller to boiler harness	
1501478	FRIIA UK Power Cord	
-----	FRIIA 230Vac complete packaging	

		Date		Name	
		Drawn	25/09/2019	U.T.	
		Checked		Standards	
		Tolleranza generali		UNI EN 22768-mk	
		Description		PTALU35mb 1-8 HP (MBS) 230Vac / Cold still	
		Material		Scale	
		Treatment			
		Tolleranza generali		04-PTALU35CAMB	
				1	
				A3	

Number	Part Number	Description	Note
1	1400831	Elbow Stem 1/4" - 1/4" (John Guest)	Water Out
2	1400827	Elbow Stem 3/8 - 3/8 (John Guest)	Water In
3	1400832	Elbow Stem 8mm - 8mm (John Guest)	CO2 In
4	1501180	FRIIA Chiller to Boiler Harness	

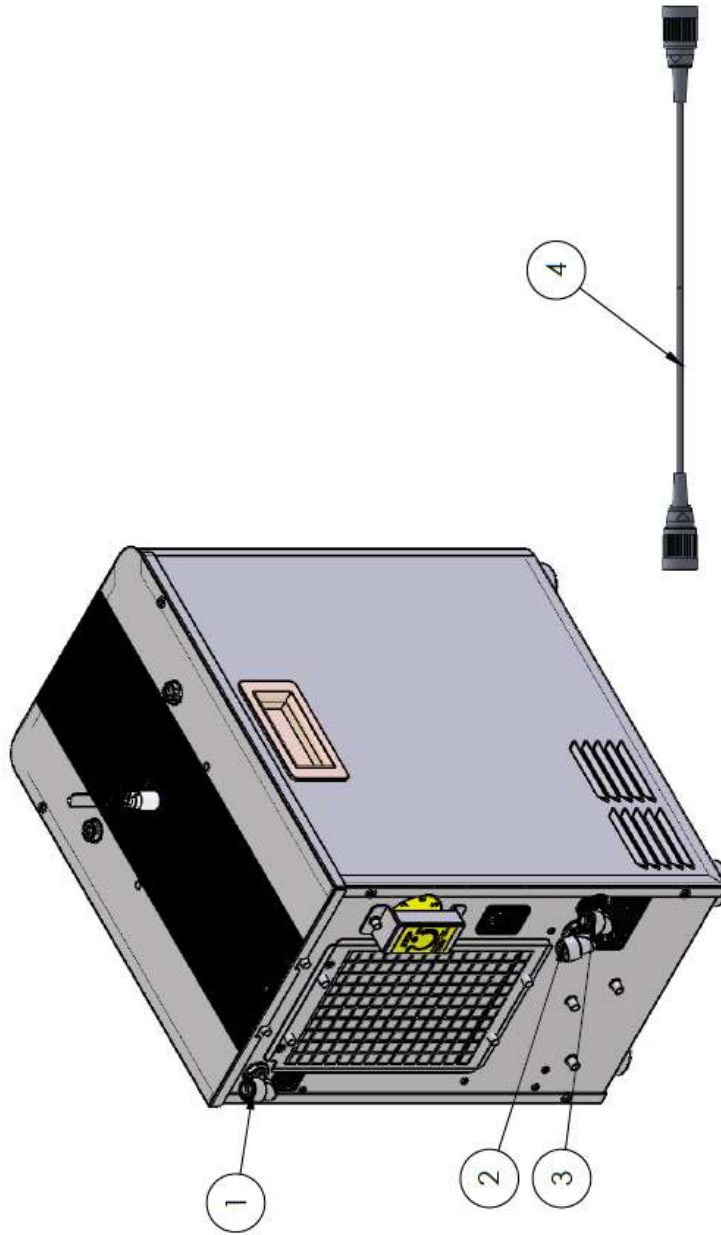

	UNLESS OTHERWISE SPECIFIED, DIMENSIONS ARE IN MILLIMETERS. TOLERANCES: LINEAR: +0.2mm ANGULAR: +0.5°	DESCRIPTION: Elbow connectors	DRAWN BY: BB	SCALE: 1:10
	DWG NO.: 1000860* 100862*		APPROVED BY: DW	
	MATERIAL: mm		REVISION: 0	CO: 578

Cabinet Ventilation

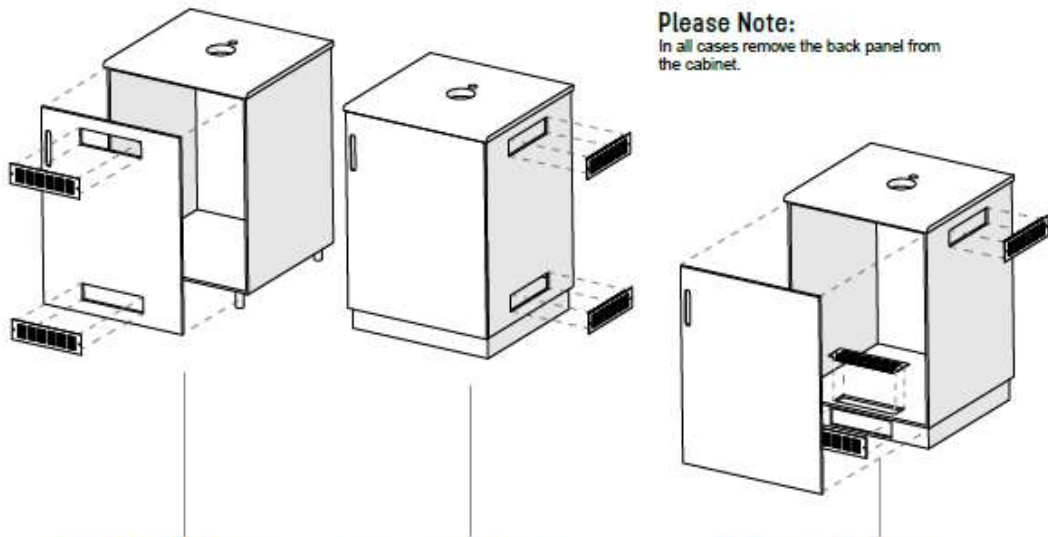

Please Note:
In all cases remove the back panel from the cabinet.

Front ventilation

Ventilation grilles cut out of standard cabinet door.

Side ventilation

Ventilation grilles cut out of standard 600mm cabinet. Grilles may be fitted on either side as long as they ventilate into an open unobstructed area.

Base ventilation

Ventilation grilles cut in base panel and base plinth, a grille must also be cut out at the top of the cabinet.

The cabinet may be ventilated in many ways provided there are cut outs placed near the base and another near the top of the cabinet to take advantage of natural circulation.

Cabinet temperature: Max 35°C, if more air is not being evacuated efficiently it may cause cooling issues or possibly damage the equipment.

Grille dimensions

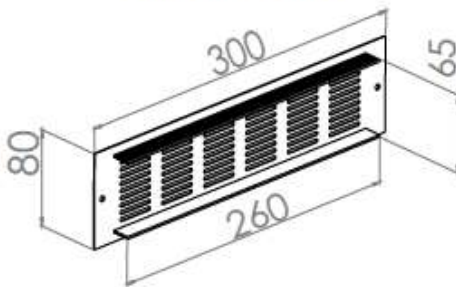

Cut out for standard 600mm door

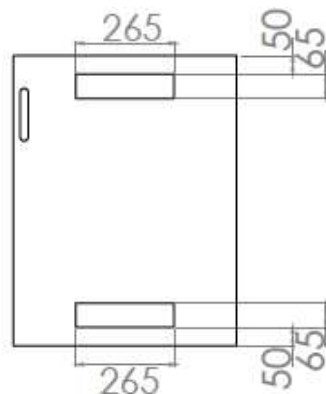

Accessories	
Part Number	Description
1600860#	FRIIA Fan Assembly (wall socket)
1600861	FRIIA Fan Assembly (chiller socket)
1860389	Cabinet Grille 300x80mm

Fan Installation

